

# Robotics Add On: IoT

Bauanleitung  
Assembly instruction  
Instructions de montage  
Bouwhandleiding  
Instrucciones de construcción  
Manual de montagem  
Istruzioni di montaggio  
Инструкция по сборке  
安装说明书

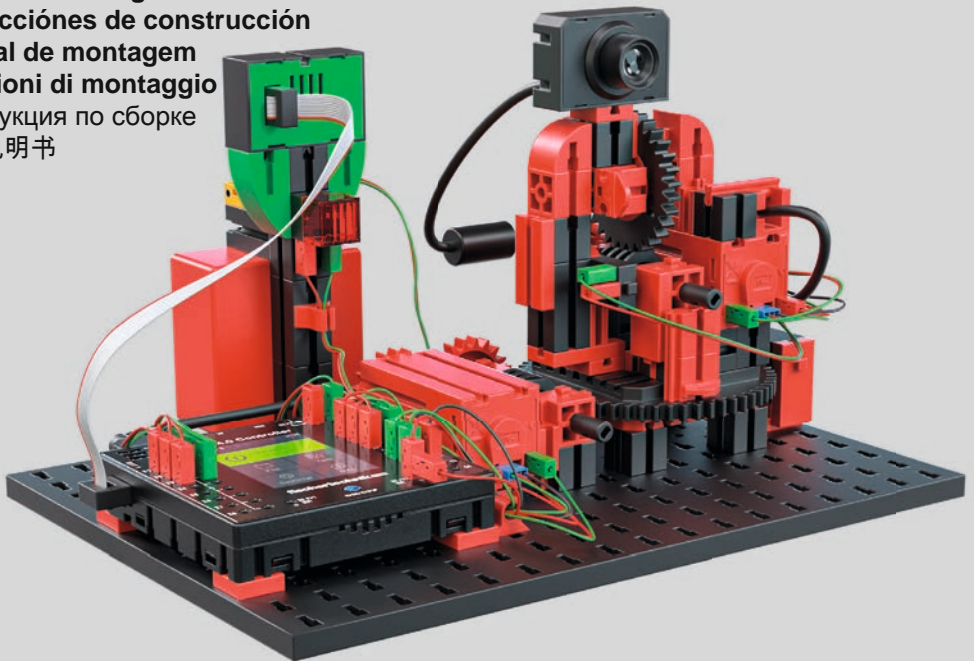

**■ Software und didaktisches Begleitmaterial:**

Auf dem fischertechnik eLearning Portal finden Sie:

- Installationshinweise zur ROBOPRO Coding App (iOS, Android, Windows, MacOS, Linux)
- Informationen zum TXT 4.0 Controller
- didaktische Begleitmaterialien für den Einsatz im Unterricht

Link zum eLearning Portal:

<https://www.fischertechnik.de/elearning-iot>

**■ Software and accompanying pedagogical materials:**

On the fischertechnik eLearning Portal, you will find:

- Installation instructions for ROBOPRO Coding App (iOS, Android, Windows, MacOS, Linux)
- Information on the TXT 4.0 Controller
- Accompanying pedagogical materials for instructional use

Link to the eLearning Portal:

<https://www.fischertechnik.de/elearning-iot>

**■ Logiciel et matériel didactique d'accompagnement:**

Dans le portail d'E-apprentissage de fischertechnik, vous trouverez:

- Des consignes d'installation de l'application ROBOPRO Coding (iOS, Android, Windows, MacOS, Linux)
- Des informations sur le contrôleur TXT 4.0
- Du matériel didactique d'accompagnement pour une utilisation pendant les cours

Lien vers le Portail d'e-formation:

<https://www.fischertechnik.de/elearning-iot>

**■ Software En didactisch begeleidingsmateriaal:**

Op het fischertechnik eLearning-portal vindt u:

- Installatieaanwijzingen voor ROBOPRO coding app (iOS, Android, Windows, MacOS, Linux)
- Informatie over TXT 4.0 controller
- didactisch begeleidingsmateriaal voor gebruik in het onderwijs

Link naar het eLearning-portal:

<https://www.fischertechnik.de/elearning-iot>

**■ Software y material didáctico:**

En el portal eLearning de fischertechnik encontrará:

- Instrucciones de instalación para la aplicación de codificación ROBOPRO (iOS, Android, Windows, MacOS, Linux)
- Información sobre los controladores TXT 4.0
- Materiales didácticos para usarlos en las clases

Enlace al portal eLearning:

<https://www.fischertechnik.de/elearning-iot>

**■ Software e material de acompanhamento didático:**

No portal de eLearning da fischertechnik, você pode encontrar:

- Dicas de instalação para o ROBOPRO Coding App (iOS, Android, Windows, MacOS, Linux)
- Informações sobre o controlador TXT 4.0
- materiais de acompanhamento didático para a aplicação em exercícios

Link para o portal de eLearning:

<https://www.fischertechnik.de/elearning-iot>

**■ Software e materiale didattico di accompagnamento:**

Sul portale di eLearning di fischertechnik potete trovare:

- Istruzioni per l'installazione di ROBOPRO Coding App (iOS, Android, Windows, MacOS, Linux)
- Informazioni sul controller TXT 4.0
- materiale didattico di accompagnamento da usare in classe

Link al portale di eLearning:

<https://www.fischertechnik.de/elearning-iot>

**■ Программное обеспечение и дидактические**

сопроводительные материалы:

На обучающем интернет-портале компании fischertechnik вы найдете:

- Инструкции по установке приложения для программирования ROBOPRO (iOS, Android, Windows, MacOS, Linux)
- Информацию о контроллере TXT 4.0
- Дидактические сопроводительные материалы для использования на занятиях

Ссылка на обучающий интернет-портал:

<https://www.fischertechnik.de/elearning-iot>

**■ 软件和教学辅助材料：**

在 fischertechnik eLearning 在线学习门户网站上您可以找到：

- ROBOPRO Coding App ( iOS、Android、Windows、MacOS、Linux ) 的安装提示
- 有关 TXT 4.0 控制器的信息
- 课堂用教学辅助材料

eLearning 在线学习门户网站的链接：















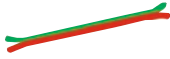
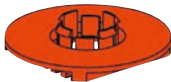







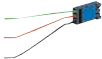



<https://www.fischertechnik.de/elearning-iot>



**Einzelteilübersicht**  
**Spare parts list**  
**Liste des pièces détachées**

**Onderdelenoverzicht**  
**Lista da piezas**  
**Resumo de peça individual**

**Singoli componenti**  
**Перечень деталей**  
**零件概览**

	31 060 3 x		32 882 5 x		137 677 4 x
	31 390 1 x		35 049 1 x		156 511 1 x
	31 391 1 x		35 063 3 x		163 201 2 x
	31 602 2 x		35 072 2 x		163 202 2 x
	31 771 1 x		36 264 1 x		168 961 1 x
	31 982 11 x		36 334 2 x		181 583 3 x
	32 064 3 x		37 468 6 x		181 584 4 x
	32 330 2 x		38 216 1 x		182 974 1 x
	32 698 1 x		38 416 1 x		
	32 881 6 x		135 465 1 x		

**Montagetips**  
**Tips for assembly**  
**Tuyaux pour le montage**

Kabel und Stecker  
 Plugs and cables  
 Fiches et des câbles

Stekkers en cables  
 Enchufes en cables  
 Cabos e contatos

Cavi e connettori  
 Провода и штекеры  
 电缆和插头

**Consigli per il montaggio**  
**Советы по сборке**  
**装配建议**

0 3cm

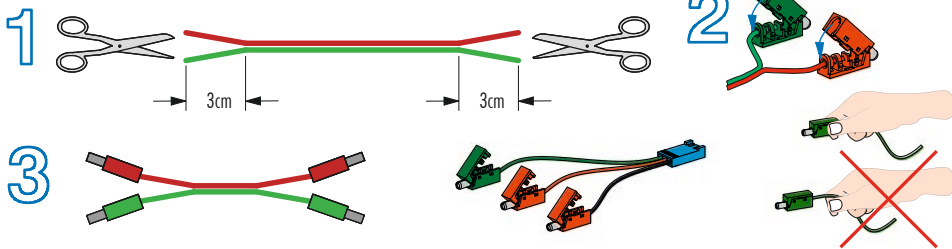

**Sicherheitshinweise**  
**Safety Information**  
**Consignes de sécurité**

**Veiligheidsrichtlijnen**  
**Indicaciones de seguridad**  
**Observações sobre segurança**

**Informazioni per la sicurezza**  
**Указания по технике безопасности**  
**安全指南**

- Alle Einzelteile, insbesondere bewegliche Teile sind falls notwendig zu warten und zu reinigen.
- All components, especially moving parts, should be maintained and cleaned as necessary.
- Toutes les pièces détachées et en particulier les pièces mobiles, sont, si nécessaire, à entretenir et à nettoyer.
- Alle onderdelen, vooral de bewegende delen, kunnen, indien noodzakelijk, onderhouden en gereinigd worden.
- Es necesario limpiar y mantener en buen estado todas las diferentes piezas -especialmente las piezas móviles.

- Caso necessário, todas as peças individuais, especialmente peças móveis, tem que ser submetidas à manutenção e ser limpidas.
- Se necessario, tutti i singoli componenti, soprattutto le parti mobili, si devono eventualmente sottoporre a manutenzione e pulizia.
- Все детали, особенно подвижные, требуют ухода и чистки.
- 必要时应保养和清洁所有零件，尤指运动部件。

- Achtung! Verletzungsgefahr an Bauteilen mit funktionsbedingten scharfen Kanten und Spitzen!
- Caution! Be careful not to hurt yourself on components with sharp or pointed edges!
- Attention! Risque de blessure sur les éléments comportant des arêtes et o pointes vives indispensables au bon fonctionnement!
- Let op! U kunt zich bezeren aan bouwstenen met scherpe randen of punten!
- Atención! ¡Cuidado, no te hagas daño con los componentes con bordes afilados o puntiagudos!

- Atenção! Perigo de ferimentos em peças componentes com cantos vivos e pontas obrigatórios para o funcionamento!
- Attention! Pericolo di lesioni dovute a componenti con spigoli vivi e punte per motivi funzionali!
- Будьте осторожны! Об острые края деталей и и наконечники можно порезаться!
- 注意！因功能需要而带有锋利的棱边和尖角的部件可能会带来受伤危险

- Nicht wiederaufladbare Batterien dürfen nicht geladen werden
- Aufladbare Batterien dürfen nur von Erwachsenen geladen werden
- Aufladbare Batterien sind aus dem Batteriehalter herauszunehmen, bevor sie geladen werden.
- Batterien müssen mit der richtigen Polarität eingelegt werden.
- Leere Batterien müssen aus dem Produkt herausgenommen werden
- Die Anschlussklemmen dürfen nicht kurzgeschlossen werden.
- Verbrauchte Batterien dem Sondermüll zuführen.
- Drähte nicht in Steckdose einführen!
- Ladegerät regelmäßig auf Schäden überprüfen.
- Bei einem Schaden darf das Ladegerät bis zur vollständigen Reparatur nicht mehr verwendet werden.

- Do not attempt to charge NON-rechargeable batteries.
- Rechargeable batteries are only to be charged by adults.
- Take rechargeable batteries out of the battery tray before charging them.
- Insert batteries with the correct polarity.
- Remove dead batteries from the product.
- Do not short circuit the connecting terminals!
- Discard spent dry cells at special waste disposal centre.
- Do not insert the wires into an outlet!
- Regularly inspect battery charger for damage.
- If the battery charger has been damaged, it should not be used further until fully repaired.

- Il est interdit de recharger des piles qui ne sont pas des accumulateurs.
- Le chargement des accumulateurs doit toujours se faire par des adultes.
- Retirer les accumulateurs du support de pile avant de les recharger.
- Veiller à la polarité correcte lors de la mise en place des piles.
- Retirer impérativement les piles ou accumulateurs vides du produit.
- Il est interdit de court-circuiter les bornes de raccordement.
- Jeter les piles usagées dans un conteneur spécial réservé à cet effet.
- Ne pas introduire les fils dans une prise!
- Contrôlez régulièrement le chargeur en vue d'éventuelles détériorations.
- En cas de détérioration, il est interdit d'utiliser le chargeur jusqu'à ce qu'il ait été intégralement réparé.

- Niet-oplaadbare batterijen mogen niet worden opgeladen.
- Oplaadbare batterijen mogen uitsluitend door volwassenen worden opgeladen.
- Oplaadbare batterijen moeten uit de batterijhouder worden verwijderd, voordat deze worden opgeladen.
- De batterijen moeten met de juiste polariteit worden geplaatst.
- Lege batterijen moeten uit het product worden verwijderd.
- De aansluitklemmen mogen niet worden kortgesloten.
- Afleveren gebruikte batterijen bij het klein chemisch afval (KCA).
- Geen draden in de contactdoos steken!
- Laadtoestel regelmatig controleren op schade.
- Bij schade mag het laadtoestel niet meer gebruikt worden tot het volledig hersteld is.

- Las pilas no recargables no pueden ser cargadas
- Las pilas recargables sólo pueden ser cargadas por un adulto
- Las pilas recargables deben ser extraídas del compartimento de pilas antes de que sean cargadas.
- Las pilas deben ser colocadas con la polaridad correcta.
- Las pilas descargadas deben ser extraídas del producto
- Los bornes de conexión no pueden ser puestos en cortocircuito.
- Retirar las baterías viejas, desechándolas en un depósito de basuras especiales.
- No introducir hilos en la toma de corriente!
- Comprobar con regularidad si el cargador presenta daños.
- En caso de presentar daños, el cargador no debe volver a ser utilizado hasta que esté completamente reparado.

- Pilhas não recarregáveis não devem ser novamente carregadas.
- Pilhas recarregáveis somente devem ser recarregadas por adultos.
- Pilhas recarregáveis devem ser retiradas do compartimento de pilhas antes de serem carregadas.
- As pilhas devem ser colocadas com a polaridade correta.
- As pilhas descarregadas devem ser retiradas do produto.
- Os terminais de conexão não devem ser curto-circuitados.
- Eliminar as baterias esgotadas como desperdício perigoso
- Nunca introduzir fios na tomada!
- Verificar regularmente se o carregador apresenta danos.
- Em caso de dano, o carregador não deverá ser utilizado enquanto não estiver plenamente consertado.

- Le batterie non ricaricabili non devono essere ricaricate
- Le batterie ricaricabili devono essere ricaricate da persone adulte
- Le batterie ricaricabili si devono estrarre dal supporto prima di ricaricarle.
- Le batterie si devono inserire rispettando la polarità.
- Togliere le batterie dal prodotto quando sono scariche
- I morsetti di allacciamento non devono essere cortocircuitati.
- Smaltire le batterie usate negli appositi contenitori per la raccolta differenziata.
- Non inserire i fili nella presa elettrica.
- Controllare periodicamente se il caricabatterie presenta dei danni.
- In caso di danni, il caricabatterie non deve più essere utilizzato fino alla riparazione.

- Не пытайтесь заряжать перезаряжаемые батарейки.
- Зарядку перезаряжаемых аккумуляторов разрешается выполнять только взрослым.
- Перед зарядкой перезаряжаемых аккумуляторов извлеките их из аккумуляторного отсека.
- При установке аккумуляторов на место соблюдайте полярность.
- Разряженные батарейки необходимо извлечь из игрушки.
- Не замыкайте коротко соединительные клеммы.
- Использованные батареи утилизировать как спецотходы.
- Не вставляйте в розетку провода!
- Регулярно проверяйте зарядное устройство на отсутствие повреждений.
- При наличии повреждений использовать зарядное устройство до выполнения его полного ремонта не разрешается.

- 不得给非充电电池充电
- 只允许由成年人给充电电池充电
- 在充电前必须将充电电池从电池夹中取出。
- 必须按照正负极正确放入电池。
- 未充电的电池必须从模型中取出
- 接线柱不允许被短路。
- 用完了的电池应作为特种垃圾处理。
- 禁止将金属丝插入插座！
- 经常检查充电器是否有损坏情况。如果充电器有损，直到完全修好为止不可以再使用。

- Die Modelle dürfen nur an Geräte der Schutzklasse II angeschlossen werden, die mit dem entsprechenden Symbol gekennzeichnet sind.
- Ensure that the models are connected only to equipment rated in protection category II and marked with the appropriate symbol.
- Le raccordement des maquettes est uniquement permis à des appareils dotés de la catégorie de protection II qui portent le pictogramme respectif.
- De modellen mogen alleen op apparaten uit beschermingsklasse II worden aangesloten, die zijn voorzien van het bijbehorende symbool.
- Los modelos sólo pueden ser conectados a aparatos de clase de protección II que están identificados con el símbolo correspondiente.
- Os modelos somente devem ser conectados nos aparelhos da classe de proteção II, que são identificados com o símbolo correspondente.
- I modelli devono essere collegati solo ad apparecchi della classe di protezione II, contrassegnati con il relativo simbolo.
- Модели можно подключать только к приборам класса защиты II, обозначенным соответствующим знаком.
- 这些模型只允许连接到具有防护等级 II 的装置上，这类装置被用相应的符号进行了标识。

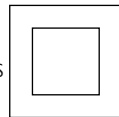

- Das Produkt darf nur mit einer der folgenden fischertechnik Energiequellen benutzt werden: Transformator für Spielzeuge (Power Set) oder Accu Pack 8,4V Art.-Nr. 35537. Der Transformator ist kein Spielzeug!
- The product may only be used with one of the following fischertechnik energy sources: Transformer for toys (Power Set) or Accu Pack 8.4V Art No. 35537. The transformer is not a toy!
- L'utilisation de ce produit n'est permis qu'avec l'une des sources d'énergie fischertechnik suivantes: transformateur pour jouets Power Set ou Art. n° : 35537 pack d'accumulateurs 8,4 volts. Le transformateur n'est pas un jouet !
- Het product mag uitsluitend met een van de volgende fischertechnik energiebronnen worden gebruikt: transformator voor speelgoed art.nr.: Power Set of art.nr.: 35537 accupack 8,4V. De transformator is geen speelgoed!
- El producto se debe utilizar únicamente con una de las siguientes fuentes de energía: Transformador para juguetes Power Set o Art. No. 35537 paquete acumulador de 8,4V. ¡El transformador no es un juguete!
- O produto somente pode ser utilizado com uma das seguintes fontes de energia da fischertechnik: transformador para brinquedos Power Set ou art. n°: 35537 Bloco de bateria de 8,4V. O transformador não é um brinquedo!
- Questo prodotto può essere utilizzato solo con le seguenti fonti di energia fischertechnik: trasformatore per giocattoli Power Set oppure cod. prod.: 35537 confezione batterie da 8,4V. Il trasformatore non è un giocattolo!
- Изделие можно использовать только с одним из следующих источников электропитания от fischertechnik: блок питания (арт. 505283) или улятор 8,4В (арт. 35537) Трансформатор - это не игрушка!
- 该商品只允许使用如下的慧鱼 (fischertechnik) 电源：货号：135719，9V DC 电池盒 货号：35537，8.4V 电池 (Accu Pack) 变压器不是一个玩具!



Hinweise zum Umweltschutz / Instructions for Environmental Protection / Remarques de protection de l'environnement / Bescherming van het milieu / Notas con respecto a la protección del medio ambiente / Instruções para a proteção do meio ambiente / Indicazioni sulla tutela ambientale / Указания по охране окружающей среды / 有关环保的提示：

[www.fischertechnik.de/environment](http://www.fischertechnik.de/environment)

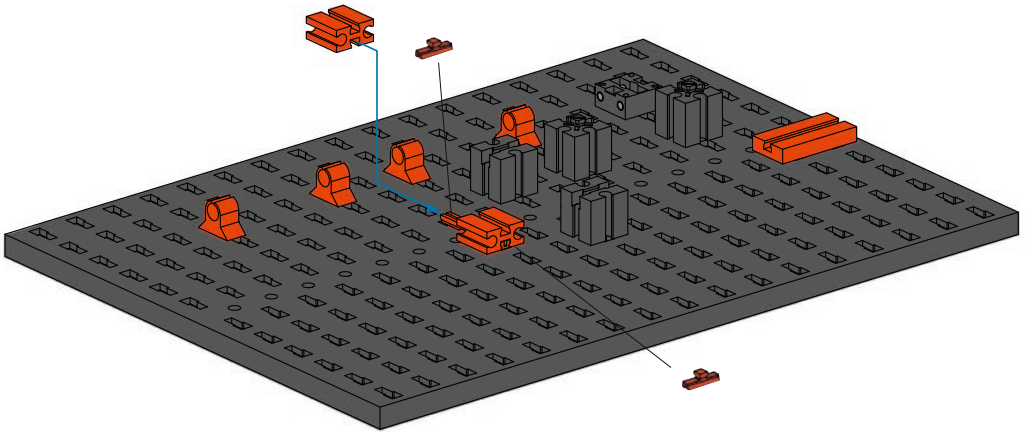
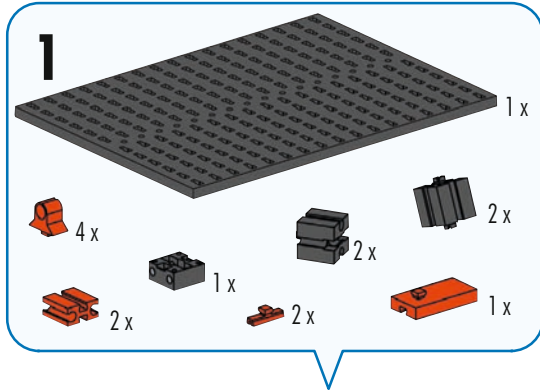
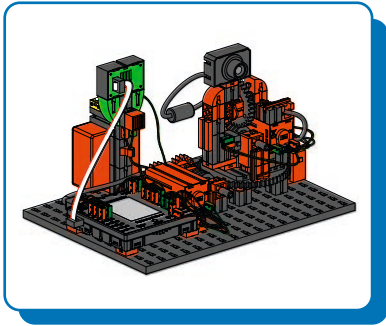

2



2x



1x



1x



1x



1x



1x



2x



1x



2x



2x





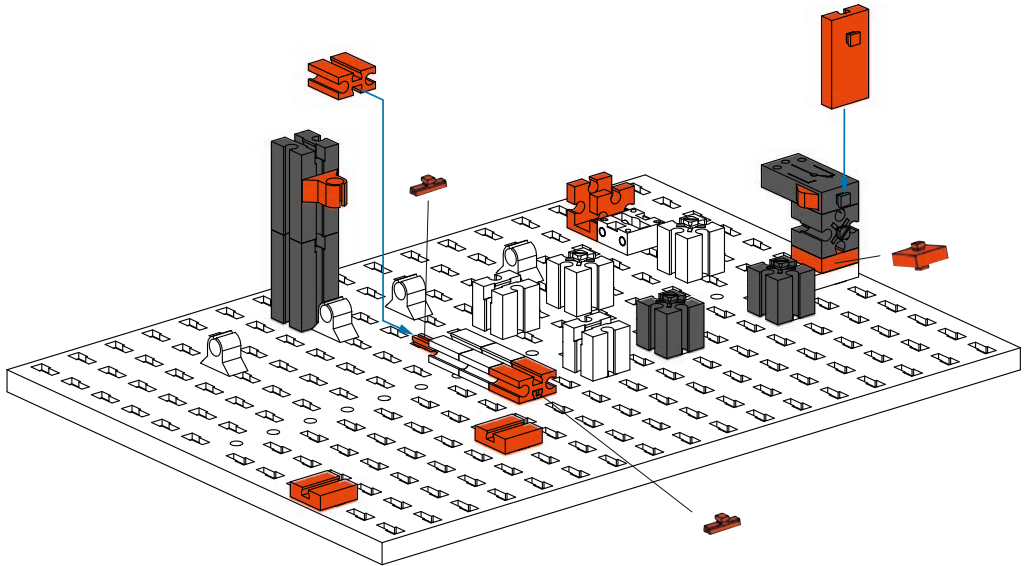

2x

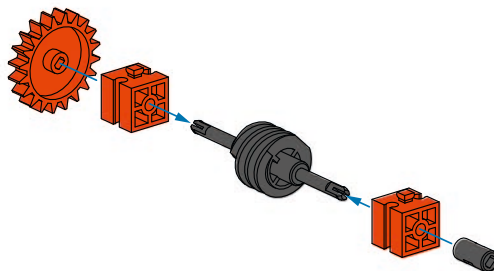
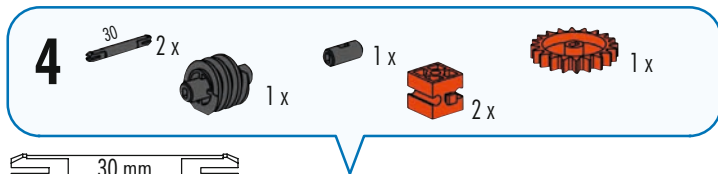
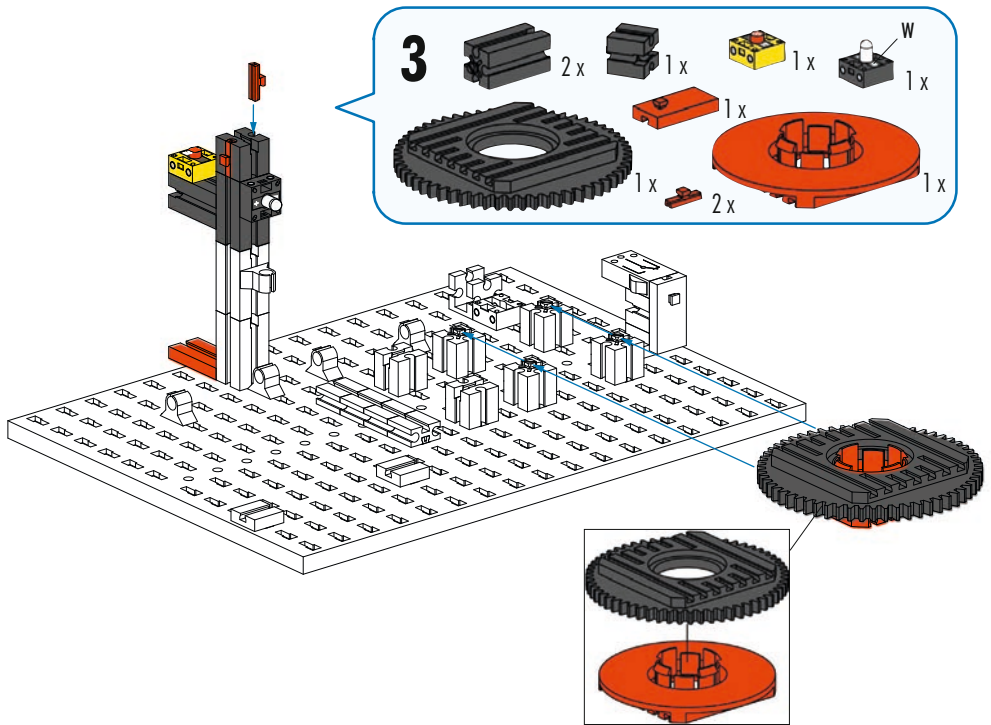







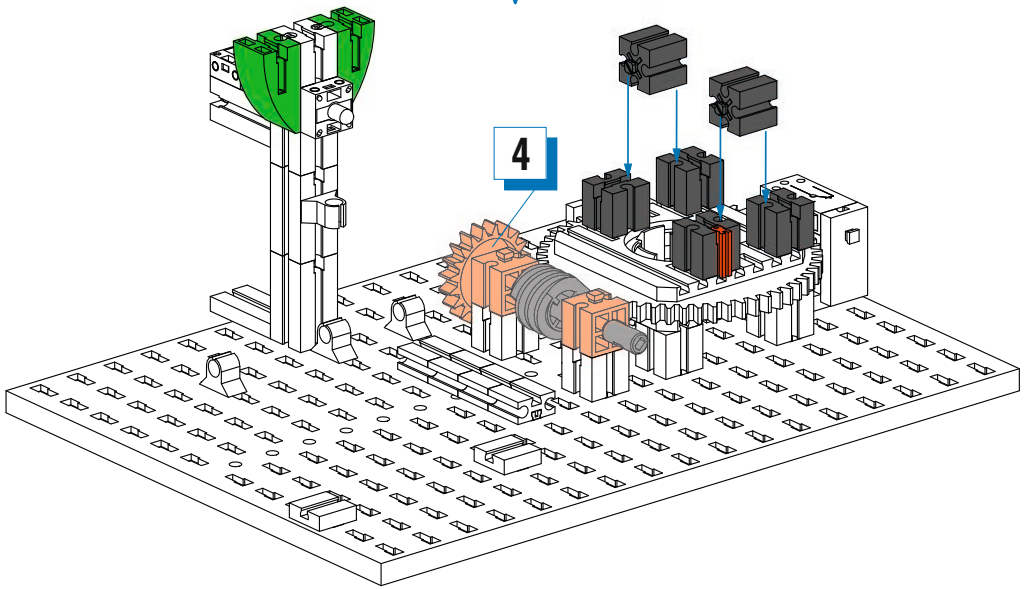

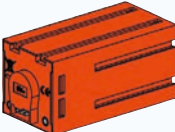
**5**  4x  2x  1x  2x



**6**  1x  1x  1x  2x

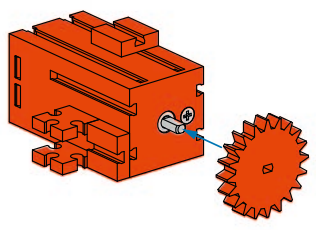

7

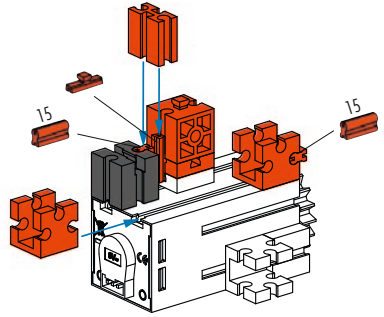

- 1x (black 2x4 Technic brick)
- 1x (orange 1x2 Technic brick)
- 2x (orange 1x2 Technic brick with hole)
- 1x (orange 1x2 Technic brick with hole)
- 1x (orange 1x2 Technic brick with hole)
- 2x (orange 1x2 Technic brick with hole)
- 1x (orange 1x2 Technic brick with hole)





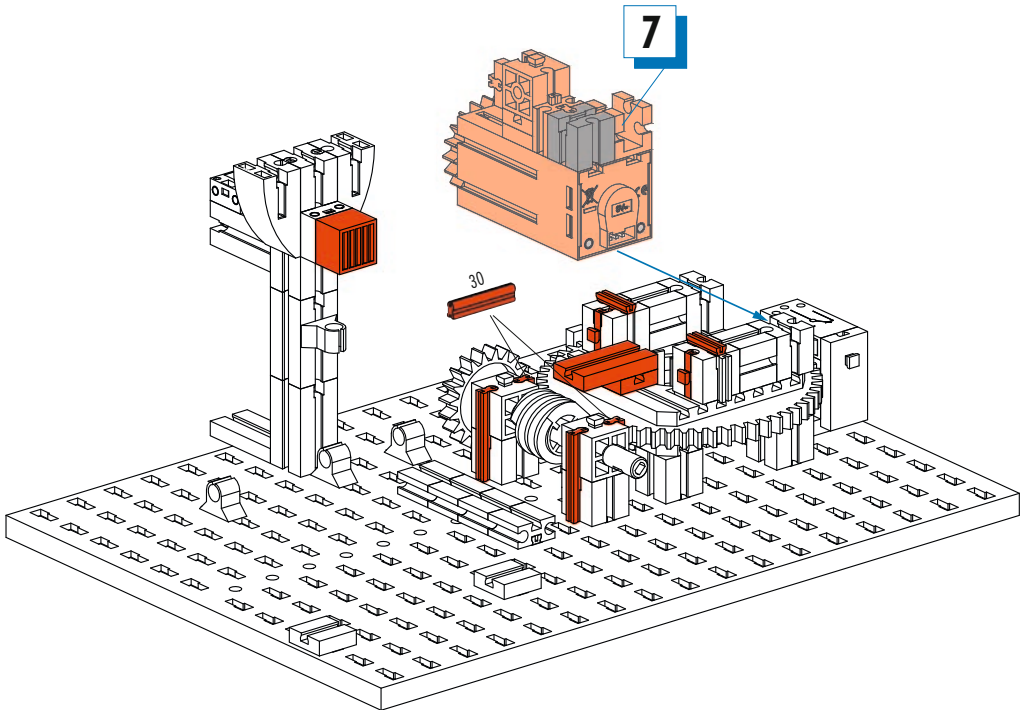

8

- 1x (orange 1x2 Technic brick)
- 1x (orange 1x4 Technic brick)
- 4x (orange 30-length Technic axle)
- 4x (orange 1x2 Technic brick with hole)
- 1x (orange 1x2 Technic brick)

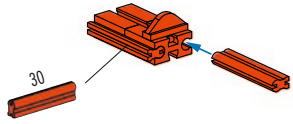

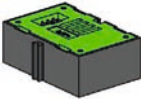
**9**  2x  30  1x



**10**  1x  1x  1x  2x  1x

**9**

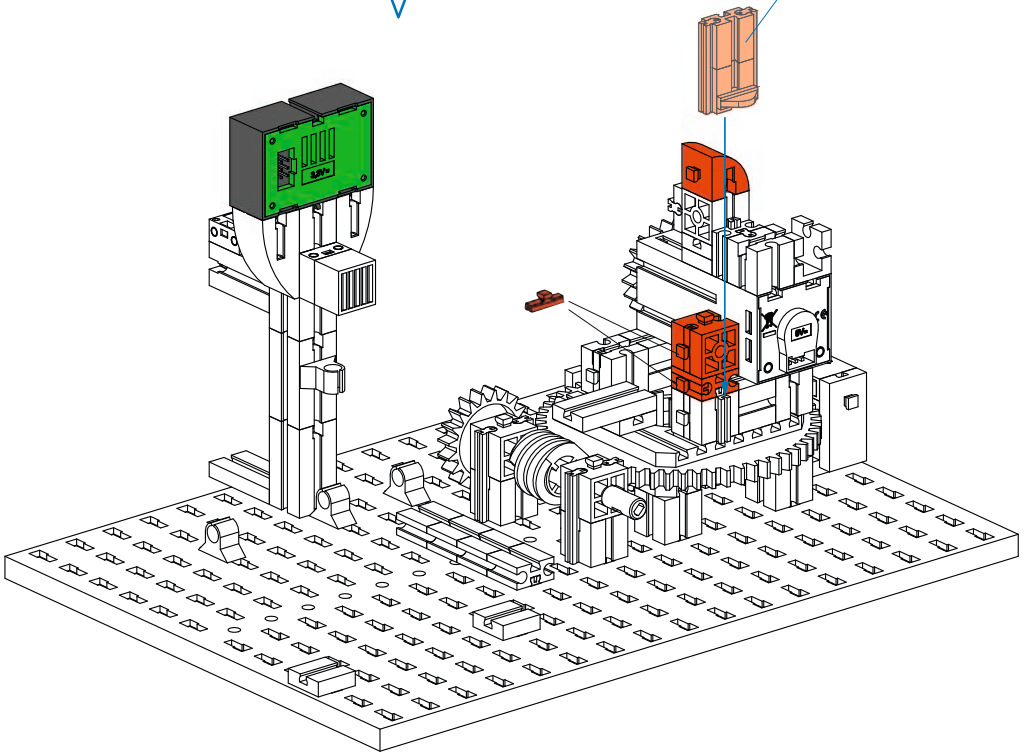

11

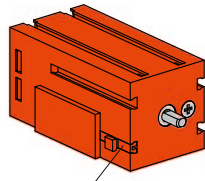
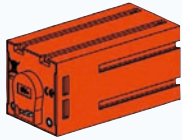

12

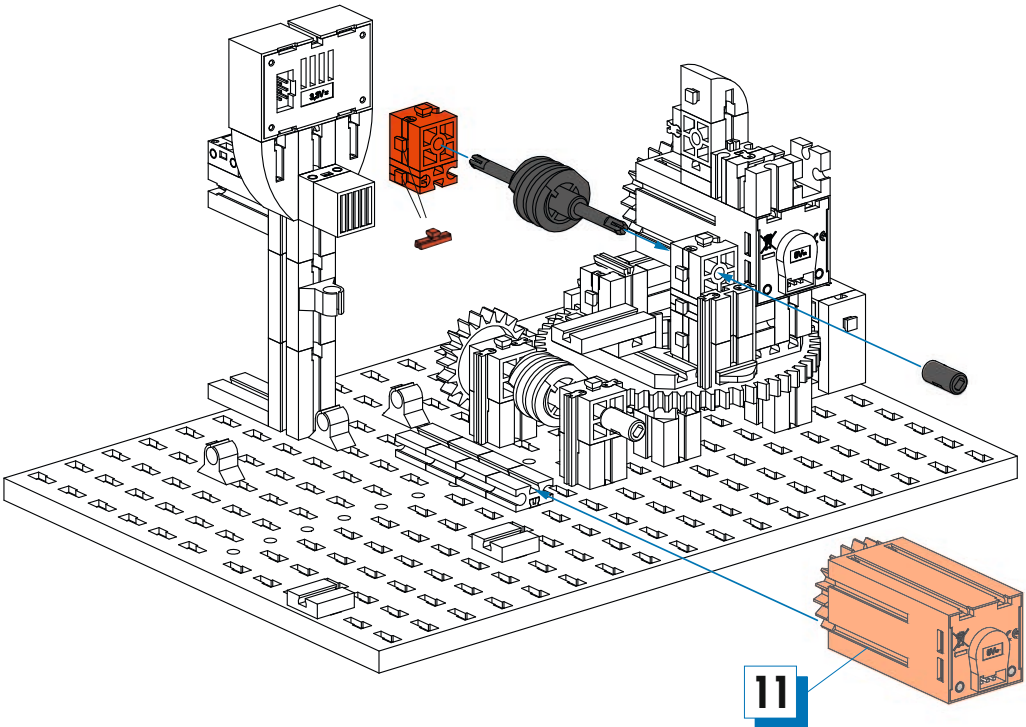
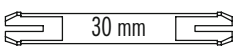

11

**13**

- 1x Gear (grey)
- 1x Pin (orange)
- 1x Pin (orange)
- 1x Pin (orange)
- 1x Pin (orange)
- 1x Pin (black)
- 1x Pin (black)

60

60 mm

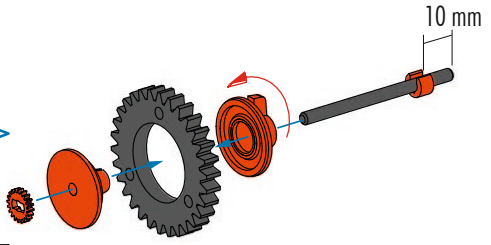

**14**

- 1x Pin (black)
- 1x Pin (black)
- 1x Pin (black)
- 1x Pin (black)
- 1x Pin (black)
- 1x Pin (black)
- 1x Pin (black)
- 1x Pin (black)

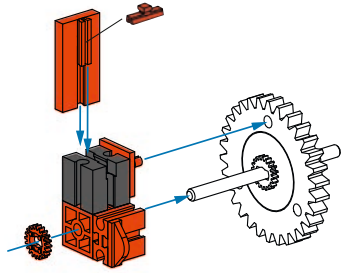

**15**

- 1x Gear (orange)
- 2x Pin (orange)
- 2x Pin (orange)

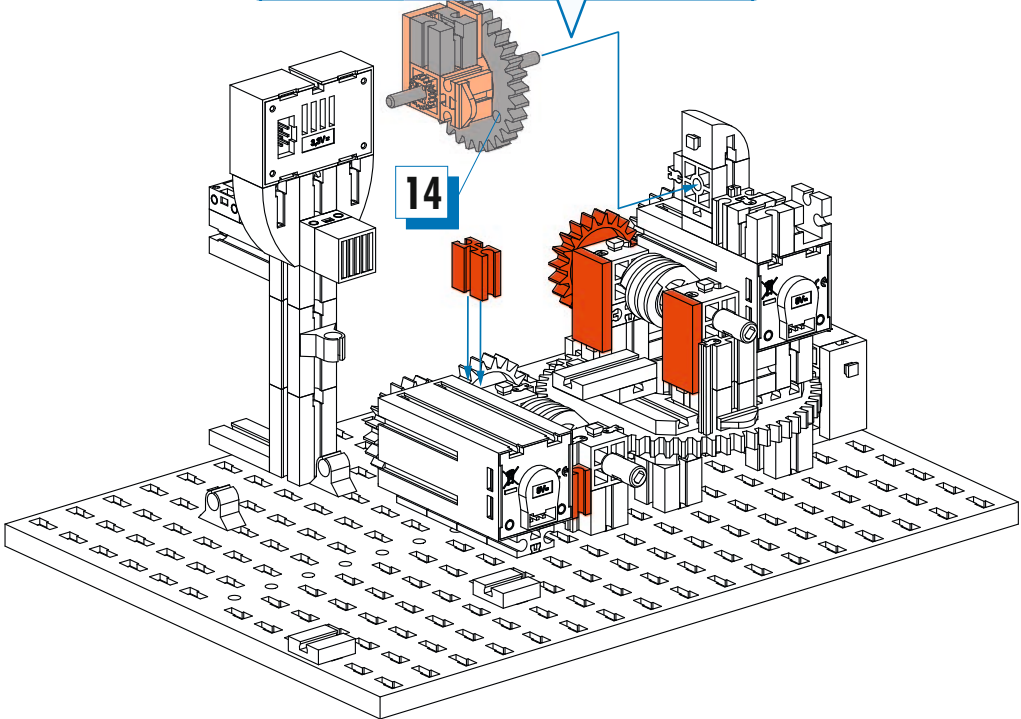

16



1x



1x

15



1x



1x



1x

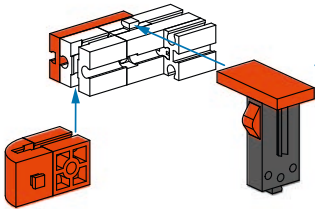
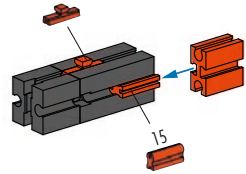

17



1x



1x



1x



1x



1x

18

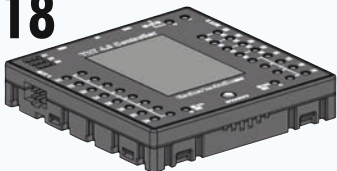



1x

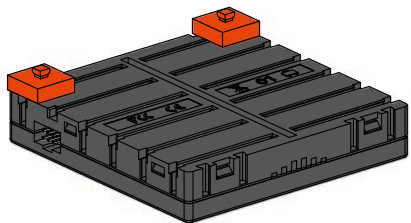

2x



**19**  1x  2x

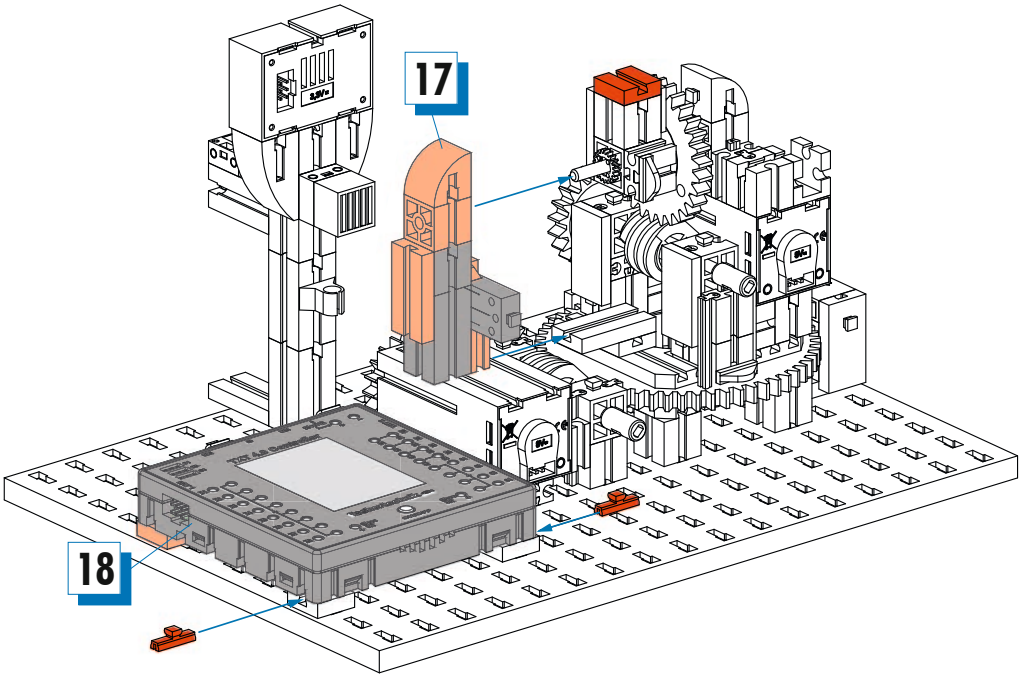



**20**

1 x

30 1 x

15 3 x

1 x

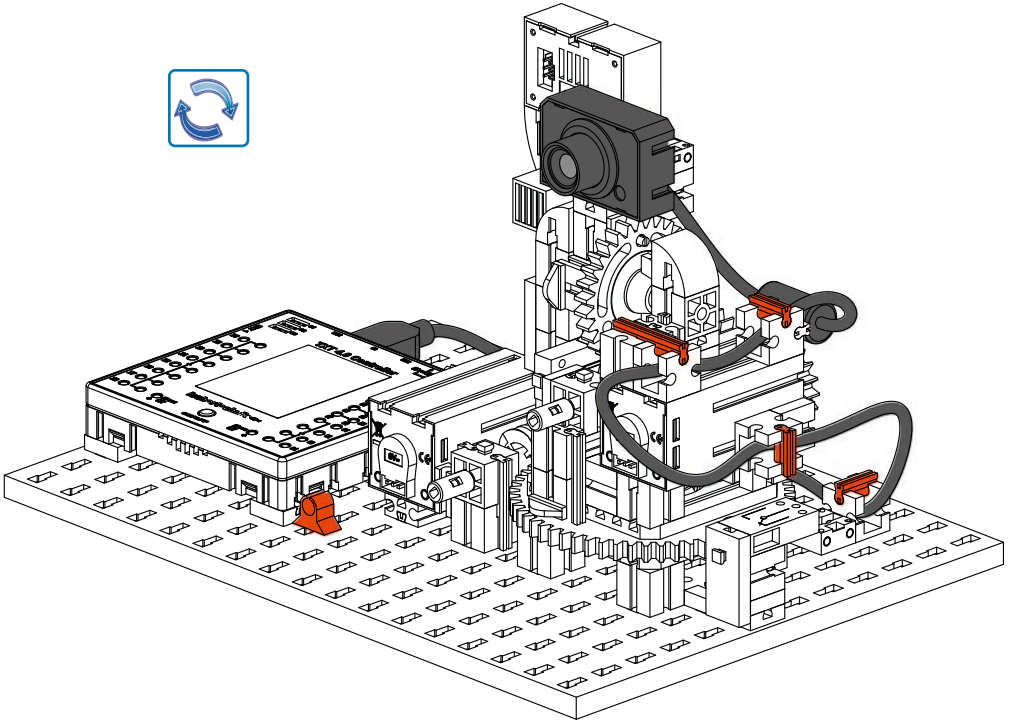

21

1 x 30 cm  
1 x 60 cm

3 x 20 cm  
4 x 30 cm  
1 x 50 cm

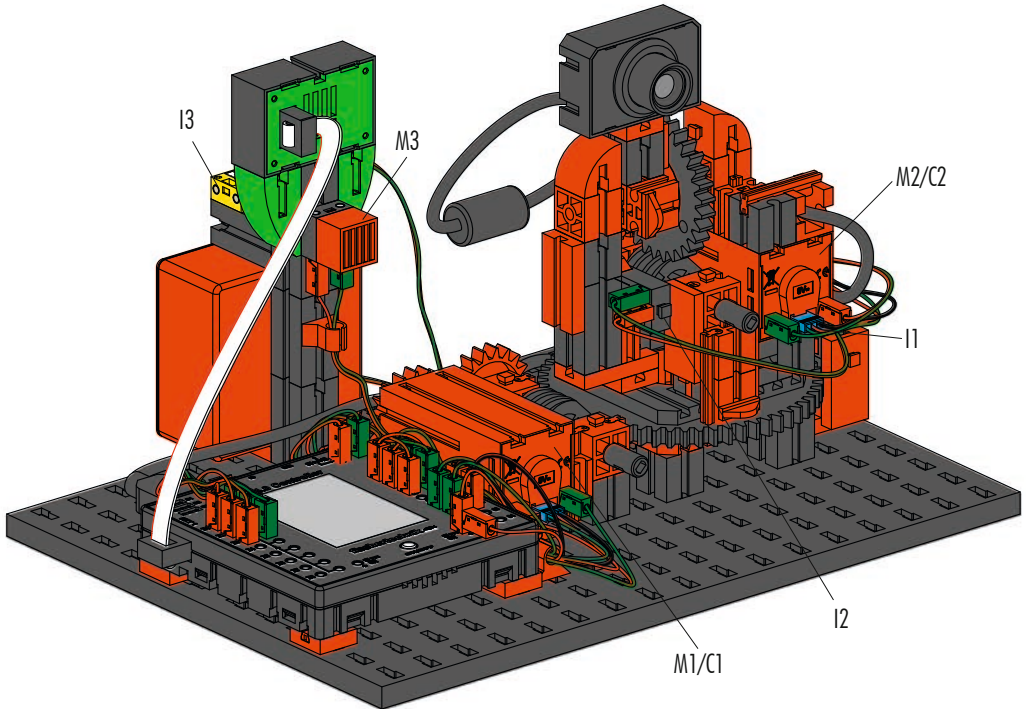

Schaltplan  
 Circuit diagram  
 Plan électrique

Schakelschema  
 Diagrama de circuitos  
 Plano elétrico de ligação

Schema elettrico  
 Схема подключения  
 电路图

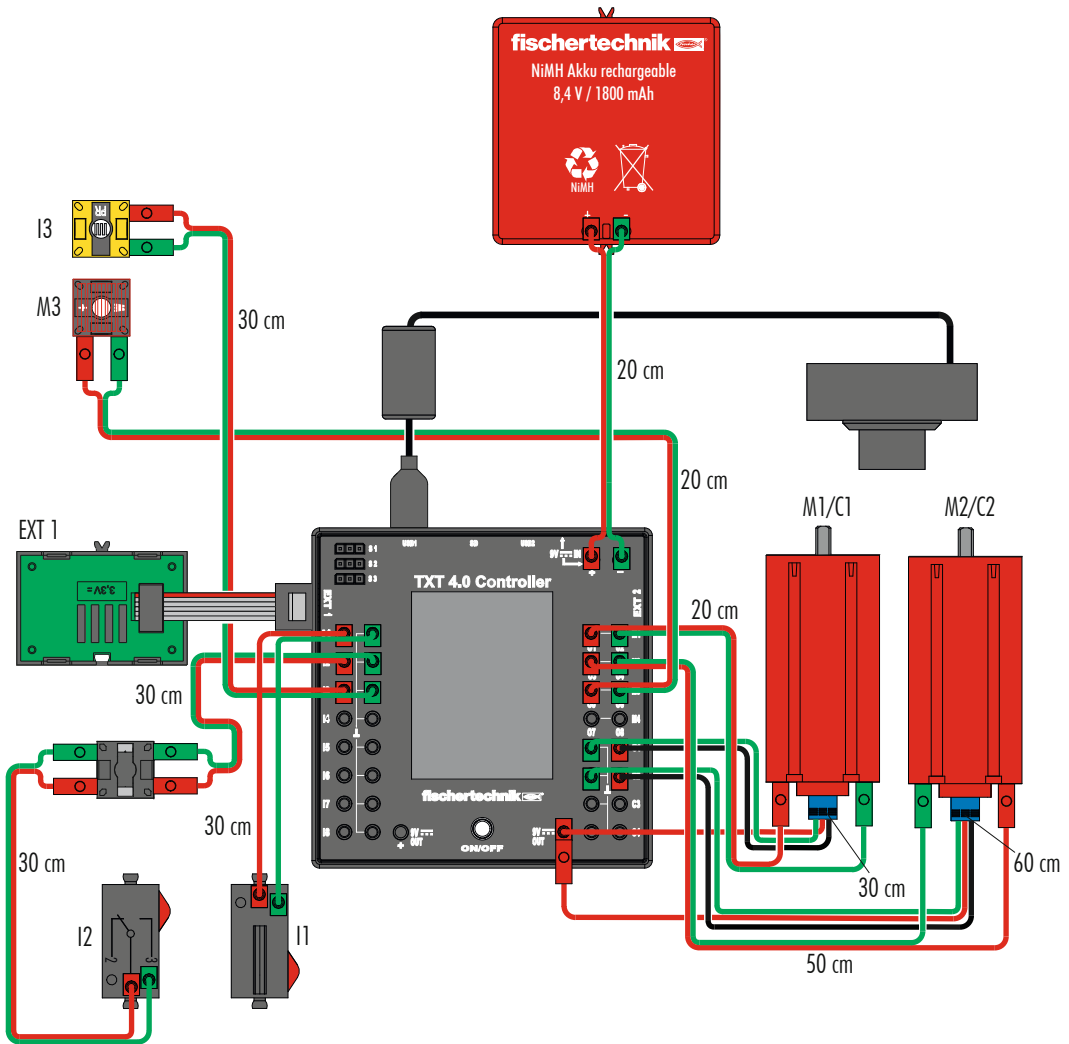

# Robotics Add On: IoT

fischertechnik GmbH  
Klaus-Fischer-Str. 1  
72178 Waldachtal  
Germany  
Phone: +49 74 43/12-43 69  
Fax: +49 74 43/12-45 91  
info@fischertechnik.de  
www.fischertechnik.de

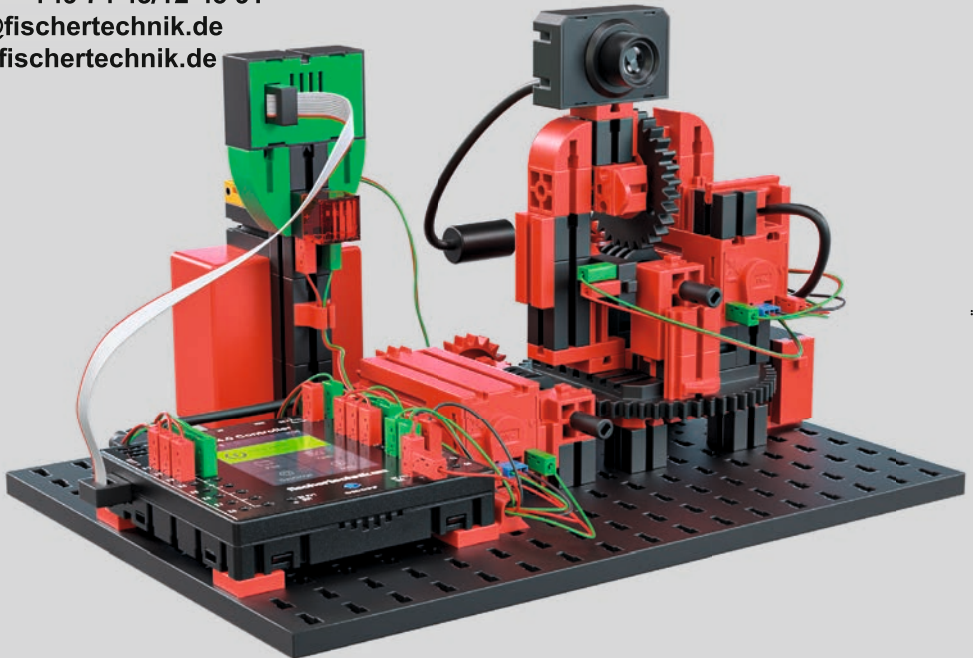

185589 - 08/21 - Co - Printed in Germany - Technische Änderungen vorbehalten - Subject to technical modifications

**S T E M** M A T H E M A T I K  
I N F O R M A T I K  
N A T U R W I S S E N S C H A F T  
T E C H N I K

 SCIENCE  TECHNOLOGY  ENGINEERING  MATHEMATICS

# 1 Model