

Robotics Add On: Competition Set

Bauanleitung
Assembly instruction
Instructions de montage
Bouwhandleiding
Instrucciones de construcción
Manual de montagem
Istruzioni di montaggio
Инструкция по сборке
安装说明书





■ **Software und didaktisches Begleitmaterial:**

Auf dem fischertechnik eLearning finden Sie:

- Installationshinweise zur ROBOPRO Coding App (iOS, Android, Windows, MacOS, Linux)
- Informationen zum TXT 4.0 Controller
- didaktische Begleitmaterialien für den Einsatz im Unterricht

Link zum eLearning: <https://www.fischertechnik.de/elearning-competition>

■ **Software and accompanying pedagogical materials:**

On the fischertechnik eLearning, you will find:

- Installation instructions for ROBOPRO Coding App (iOS, Android, Windows, MacOS, Linux)
- Information on the TXT 4.0 Controller
- Accompanying pedagogical materials for instructional use

Link to the eLearning: <https://www.fischertechnik.de/elearning-competition>

■ **Logiciel et matériel didactique d'accompagnement:**

Dans d'E-apprentissage de fischertechnik, vous trouverez:

- Des consignes d'installation de l'application ROBOPRO Coding (iOS, Android, Windows, MacOS, Linux)
- Des informations sur le contrôleur TXT 4.0
- Du matériel didactique d'accompagnement pour une utilisation pendant les cours

Lien vers d'e-formation: <https://www.fischertechnik.de/elearning-competition>

■ **Software En didactisch begeleidingsmateriaal:**

Op het fischertechnik eLearning vindt u:

- Installatieaanwijzingen voor ROBOPRO coding app (iOS, Android, Windows, MacOS, Linux)
- Informatie over TXT 4.0 controller
- didactisch begeleidingsmateriaal voor gebruik in het onderwijs

Link naar het eLearning: <https://www.fischertechnik.de/elearning-competition>

■ **Software y material didáctico:**

En el eLearning de fischertechnik encontrará:

- Instrucciones de instalación para la aplicación de codificación ROBOPRO (iOS, Android, Windows, MacOS, Linux)
- Información sobre los controladores TXT 4.0
- Materiales didácticos para usarlos en las clases

Enlace al eLearning: <https://www.fischertechnik.de/elearning-competition>

■ **Software e material de acompanhamento didático:**

No eLearning da fischertechnik, você pode encontrar:

- Dicas de instalação para o ROBOPRO Coding App (iOS, Android, Windows, MacOS, Linux)
- Informações sobre o controlador TXT 4.0
- materiais de acompanhamento didático para a aplicação em exercícios

Link para eLearning: <https://www.fischertechnik.de/elearning-competition>

■ **Software e materiale didattico di accompagnamento:**

Sul eLearning di fischertechnik potete trovare:

- Istruzioni per l'installazione di ROBOPRO Coding App (iOS, Android, Windows, MacOS, Linux)
- Informazioni sul controller TXT 4.0
- materiale didattico di accompagnamento da usare in classe

Link al eLearning: <https://www.fischertechnik.de/elearning-competition>

■ Программное обеспечение и дидактические сопроводительные материалы:

На обучающем интернет-портале компании fischertechnik вы найдете:

- Инструкции по установке приложения для программирования ROBOPRO (iOS, Android, Windows, MacOS, Linux)
- Информацию о контроллере TXT 4.0
- Дидактические сопроводительные материалы для использования на занятиях

Ссылка на обучающий интернет-портал: <https://www.fischertechnik.de/elearning-competition>

■ 软件和教学辅助材料：

在 fischertechnik eLearning 在线学习门户网站上您可以找到：





- ROBOPRO Coding App (iOS、Android、Windows、MacOS、Linux) 的安装提示
- 有关 TXT 4.0 控制器的信息
- 课堂用教学辅助材料

eLearning 在线学习门户网站的链接：<https://www.fischertechnik.de/elearning-competition>



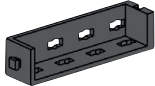







Einzelteilübersicht
Spare parts list
Liste des pièces détachées

	31 790 58 x
	31 983 4 x
	32 330 2 x
	32 879 10 x
	32 882 1 x
	35 062 2 x

Onderdelenoverzicht
Lista de piezas
Resumo de peça individual

	35 064 4 x
	36 921 2 x
	36 922 6 x
	37 238 5 x
	38 240 3 x
	38 242 2 x

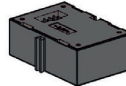
Singoli componenti
Перечень деталей
零件概览

	38 246 6 x		181 583 1 x
	38 464 4 x		181 584 2 x
	128 659 118 x		183 267 1 x
	133 009 1 x		186 175 2 x
	135 465 2 x		201 257 1 x
	137 677 6 x		

Montagetipps
Tips for assembly
Tuyaux pour le montage

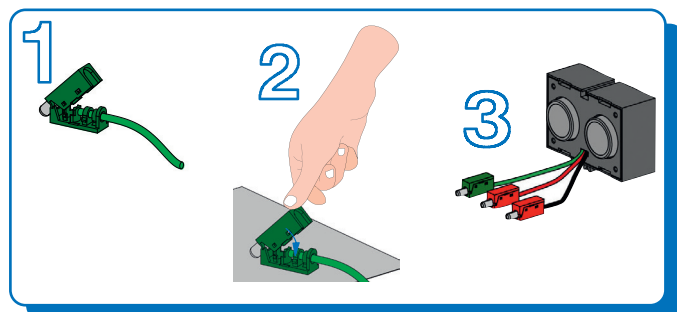

Montagetipps
Consejos para el montaje
"Dicas" para montagem

Consigli per il montaggio
Советы по сборке
装配建议

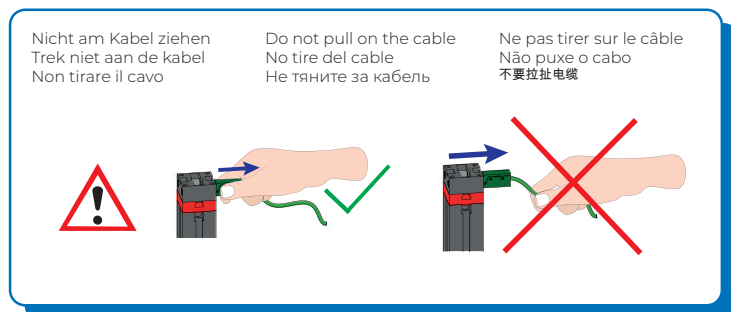

Sicherheitshinweise
Safety Information
Consignes de sécurité

Veiligheidsrichtlijnen
Indicaciones de seguridad
Observações sobre segurança

Informazioni per la sicurezza
Указания по технике безопасности
安全指南

- Achtung! Verletzungsgefahr an Bauteilen mit funktionsbedingten scharfen Kanten und Spitzen!
- Caution! Be careful not to hurt yourself on components with sharp or pointed edges!
- Attention! Risque de blessure sur les éléments comportant des arêtes et o pointes vives indispensables au bon fonctionnement!
- Let op! U kunt zich bezeren aan bouwstenen met sjerpe randen of punten!
- Atención! ¡cuidado, no te hagas daño con los componentes con bordes afilados o puntiagudos!

- Atencão! Perigo de ferimentos em peças componentes com cantos vivos e pontas obrigatórios para o funcionamento!
- Attenzione! Pericolo di lesioni dovute a componenti con spigoli vivi e punte per motivi funzionali!
- Будьте осторожны! Об острые края деталей и и наконечники можно порезаться!
- 注意！因功能需要而带有锋利的棱边和尖角的部件可能会带来受伤危险！

- Alle Einzelteile, insbesondere bewegliche Teile sind falls notwendig zu warten und zu reinigen.
- All components, especially moving parts, should be maintained and cleaned as necessary.
- Toutes les pièces détachées et en particulier les pièces mobiles, sont, si nécessaire, à entretenir et à nettoyer.
- Alle onderdelen, vooral de bewegende delen, kunnen, indien noodzakelijk, onderhouden en gereinigd worden.
- Es necesario limpiar y mantener en buen estado todas las diferentes piezas - especialmente las piezas móviles.

- Caso necessário, todas as peças individuais, especialmente peças móveis, tem que ser submetidas à manutenção e ser limpadas.
- Se necessario, tutti i singoli componenti, soprattutto le parti mobili, si devono eventualmente sottoporre a manutenzione e pulizia.
- Все детали, особенно подвижные, требуют ухода и чистки.
- 必要时应保养和清洁所有零件，尤指运动部件。

Sicherheitshinweise Safety Information Consignes de sécurité

Veiligheidsrichtlijnen Indicaciones de seguridad Observações sobre segurança

Informazioni per la sicurezza Указания по технике безопасности 安全指南

- Das Produkt darf nur mit einer der folgenden fischertechnik Energiequellen benutzt werden: Power Set oder Art.-Nr.: 35537 Accu Pack 8,4V.
- The product may only be used with one of the following fischertechnik energy sources: Power Set or Art No.: 35537 Accu Pack 8.4V. You are not allowed to use 9V NiMH accu packs in this product.
- L'utilisation de ce produit n'est permis qu'avec l'une des sources d'énergie fischertechnik suivantes: Power Set ou Art. n°: 35537 pack d'accumulateurs 8,4 volts.
- Het product mag uitsluitend met een van de volgende fischertechnik energiebronnen worden gebruikt: art.nr.: Power Set of art.nr.: 35537 accupack 8,4V
- El producto se debe utilizar únicamente con una de las siguientes fuentes de energía: Power Set o Art. No. 35537 paquete acumulador de 8,4V.
- O produto somente pode ser utilizado com uma das seguintes fontes de energia da fischertechnik: Power Set ou art. n°: 35537 Bloco de bateria de 8,4V.
- Questo prodotto può essere utilizzato solo con le seguenti fonti di energia fischertechnik: Power Set oppure cod. prod.: 35537 confezione batterie da 8,4V.
- Изделие можно использовать только с одним из следующих источников электропитания от fischertechnik: блок питания (арт. 505283) или улятор 8,4В (арт. 35537)
- 该商品只允许使用如下的慧鱼 (fischertechnik) 电源: 货号: 135719, 9V DC 电池盒 货号: 35537, 8.4V 电池 (Accu Pack)

- Die Modelle dürfen nur an Geräte der Schutzklasse II angeschlossen werden, die mit dem entsprechenden Symbol gekennzeichnet sind.
- Ensure that the models are connected only to equipment rated in protection category II and marked with the appropriate symbol.
- Le raccordement des maquettes est uniquement permis à des appareils dotés de la catégorie de protection II qui portent le pictogramme respectif.
- De modellen mogen alleen op apparaten uit beschermingsklasse II worden aangesloten, die zijn voorzien van het bijbehorende symbool.
- Los modelos sólo pueden ser conectados a aparatos de clase de protección II que están identificados con el símbolo correspondiente.
- Os modelos somente devem ser conectados nos aparelhos da classe de proteção II, que são identificados com o símbolo correspondente.
- I modelli devono essere collegati solo ad apparecchi della classe di protezione II, contrassegnati con il relativo simbolo.
- Модели можно подключать только к приборам класса защиты II, обозначенным соответствующим знаком.
- 这些模型只允许连接到具有防护等级 II 的装置上, 这类装置被用相应的符号进行了标识。

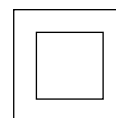

- Nicht wiederaufladbare Batterien dürfen nicht geladen werden
- Aufladbare Batterien dürfen nur von Erwachsenen geladen werden
- Aufladbare Batterien sind aus dem Batteriehalter herauszunehmen, bevor sie geladen werden.
- Batterien müssen mit der richtigen Polarität eingelegt werden.
- Leere Batterien müssen aus dem Produkt herausgenommen werden
- Die Anschlussklemmen dürfen nicht kurzgeschlossen werden.
- Verbrauchte Batterien dem Sondermüll zuführen.
- Drähte nicht in Steckdose einführen!
- Ladegerät regelmäßig auf Schäden überprüfen. Bei einem Schaden darf das Ladegerät bis zur vollständigen Reparatur nicht mehr verwendet werden.
- Alle elektrischen Bauteile (Motoren, Lampen) dürfen ausschließlich an Stromversorgungen von fischertechnik angeschlossen werden.
- Niet-oplaadbare batterijen mogen niet worden opgeladen.
- Oplaadbare batterijen mogen uitsluitend door volwassenen worden opgeladen.
- Oplaadbare batterijen moeten uit de batterijhouder worden verwijderd, voordat deze worden opgeladen.
- De batterijen moeten met de juiste polariteit worden geplaatst.
- Lege batterijen moeten uit het product worden verwijderd.
- De aansluitklemmen mogen niet worden kortgesloten.
- Afleveren gebruikte batterijen bij het klein chemisch afval (KCA).
- Geen draden in de contactdoos steken!
- Laadtoestel regelmatig controleren op schade. Bij schade mag het laadtoestel niet meer gebruikt worden tot het volledig hersteld is.
- Alle elektrische componenten (motoren, lampen) mogen uitsluitend op stroomvoorzieningen van fischertechnik worden aangesloten.
- Le batterie non ricaricabili non devono essere ricaricate
- Le batterie ricaricabili devono essere ricaricate da persone adulte
- Le batterie ricaricabili si devono estrarre dal supporto prima di ricaricarle.
- Le batterie si devono inserire rispettando la polarità.
- Togliere le batterie dal prodotto quando sono scariche
- I morsetti di allacciamento non devono essere cortocircuitati.
- Smaltire le batterie usate negli appositi contenitori per la raccolta differenziata.
- Non inserire i fili nella presa elettrica.
- Controllare periodicamente se il caricabatterie presenta dei danni. In caso di danni, il caricabatterie non deve più essere utilizzato fino alla riparazione.
- Tutti i componenti elettrici (motori, lampadine) devono essere collegati esclusivamente ad alimentatori fischertechnik.
- Do not attempt to charge NON-rechargeable batteries.
- Rechargeable batteries are only to be charged by adults.
- Take rechargeable batteries out of the battery tray before charging them.
- Insert batteries with the correct polarity.
- Remove dead batteries from the product.
- Do not short circuit the connecting terminals!
- Discard spent dry cells at special waste disposal centre.
- Do not insert the wires into an outlet!
- Regularly inspect battery charger for damage. If the battery charger has been damaged, it should not be used further until fully repaired.
- No electrical components (motors, lamps) are to be connected to any other power supply than that provided by fischertechnik.
- Las pilas no recargables no pueden ser cargadas
- Las pilas recargables sólo pueden ser cargadas por un adulto
- Las pilas recargables deben ser extraídas del compartimento de pilas antes de que sean cargadas.
- Las pilas deben ser colocadas con la polaridad correcta.
- Las pilas descargadas deben ser extraídas del producto
- Los bornes de conexión no pueden ser puestos en cortocircuito.
- Retirar las baterías viejas, desechándolas en un depósito de basuras especiales.
- No introducir hilos en la toma de corriente!
- Comprobar con regularidad si el cargador presenta daños. En caso de presentar daños, el cargador no debe volver a ser utilizado hasta que esté completamente reparado.
- Todos los componentes eléctricos (motores, luces) deben conectarse a la alimentación de corriente de la técnica Fischer exclusivamente.
- Pilhas não recarregáveis não devem ser novamente carregadas.
- Pilhas recarregáveis somente devem ser recarregadas por adultos.
- Pilhas recarregáveis devem ser retiradas do compartimento de pilhas antes de serem carregadas.
- As pilhas devem ser colocadas com a polaridade correta.
- As pilhas descarregadas devem ser retiradas do produto.
- Os terminais de conexão não devem ser curto-circuitados.
- Eliminar as baterias esgotadas como desperdício perigoso
- Nunca introduzir fios na tomada!
- Verificar regularmente se o carregador apresenta danos. Em caso de dano, o carregador não deverá ser utilizado enquanto não estiver plenamente consertado.
- Todas as peças componentes elétricas (motores, lâmpadas) só podem ser exclusivamente conectadas em abastecimentos de corrente da Fischertechnik.
- Не пытайтесь заряжать перезаряжаемые батарейки.
- Зарядку перезаряжаемых аккумуляторов разрешается выполнять только взрослым.
- Перед зарядкой перезаряжаемых аккумуляторов извлеките их из аккумуляторного отсека.
- При установке аккумуляторов на место соблюдайте полярность.
- Разряженные батарейки необходимо извлечь из игрушки.
- Не замыкайте накоротко соединительные клеммы.
- Использованные батареи утилизировать как спецотходы.
- Не вставляйте в розетку провода!
- Регулярно проверяйте зарядное устройство на отсутствие повреждений. При наличии повреждений использовать зарядное устройство до выполнения его полного ремонта не разрешается.
- Все электрические детали (электромоторы, лампочки.) можно подключать только к источникам электропитания от fischertechnik.
- 不得给非充电电池充电
- 只允许由成年人给充电电池充电
- 在充电前必须将充电电池从电池夹中取出。
- 必须按照正负极正确放入电池。
- 未充电的电池必须从模型中取出
- 接线柱不允许被短路。
- 用完了的电池应作为特种垃圾处理。
- 禁止将金属丝插入插座!
- 经常检查充电器是否有损坏情况。如果充电器有损, 直到完全修好为止不可以再使用。
- 电气元件 (传感器、电机、灯泡) 必须连接到fischertechnik的电源上



Hinweise zum Umweltschutz / Instructions for Environmental Protection / Remarques de protection de l'environnement / Bescherming van het milieu / Notas con respecto a la protección del medio ambiente / Instruções para a proteção do meio ambiente / Indicazioni sulla tutela ambientale / Указания по охране окружающей среды / 有关环保的提示 :

www.fischertechnik.de/environment

Schaltplan
Circuit diagram
Plan électrique

Schakelschema
Diagrama de circuitos
Plano elétrico de ligação

Schema elettrico
Схема подключения
电路图

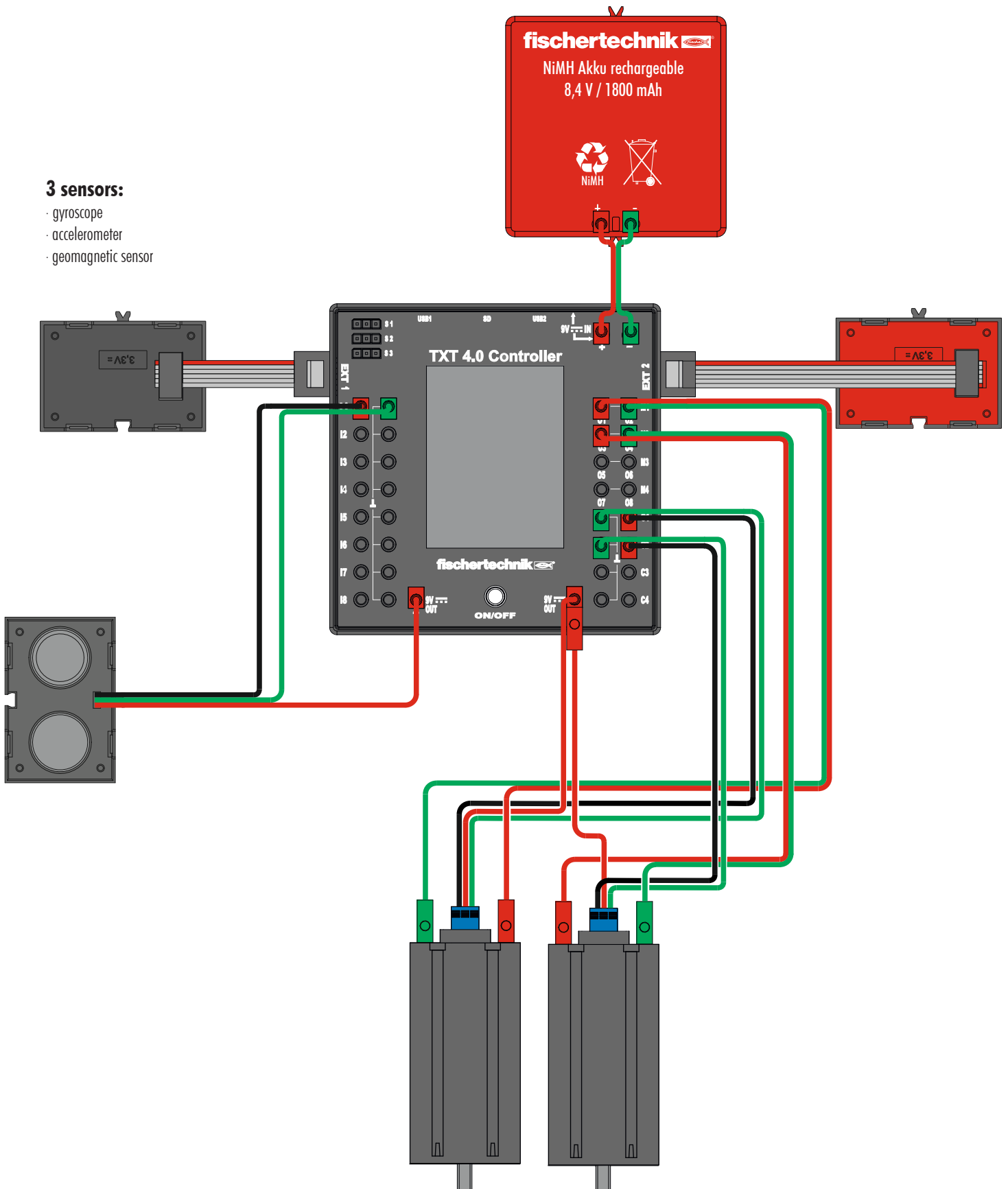

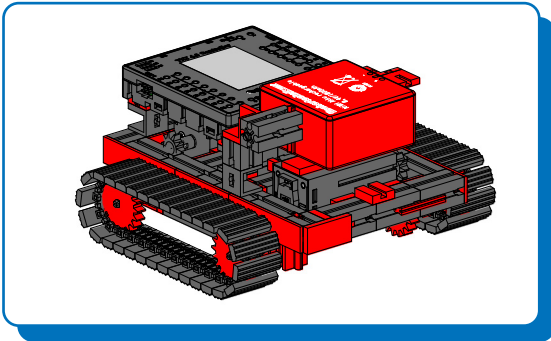

Fahrgestell Raupenfahrzeug
Chassis crawler
Véhicule à chenilles à châssis

Chassis rupsvoertuig
Vehículo de oruga con chasis
Veículo chassi sobre esteiras

Veicolo cingolato a telaio
Шасси гусеничной машины
底盘式履带车

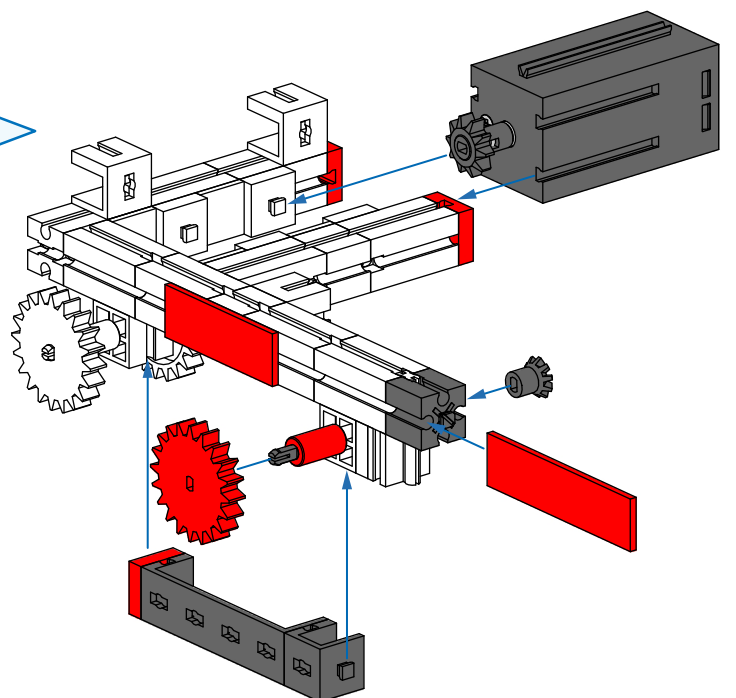
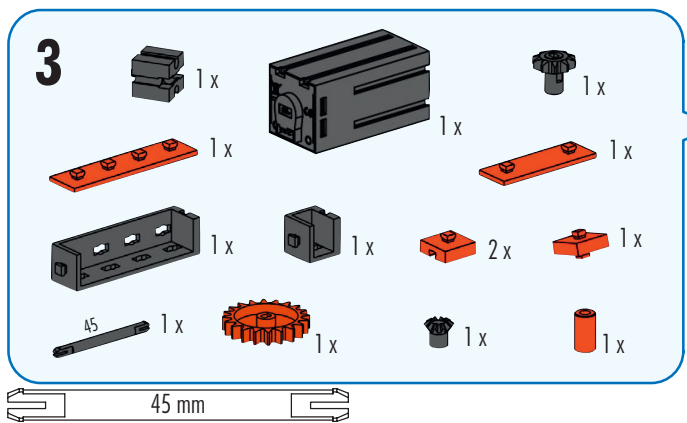
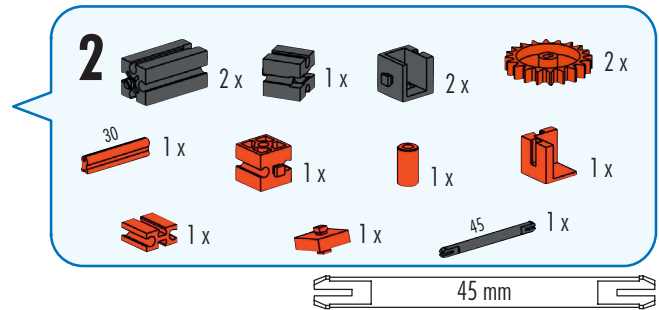
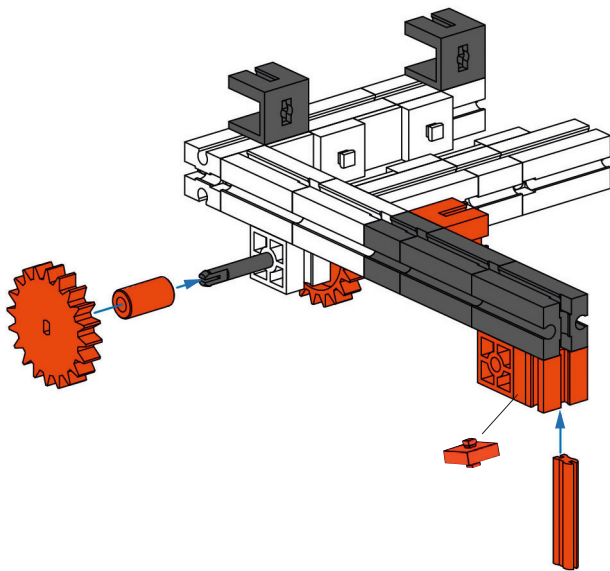
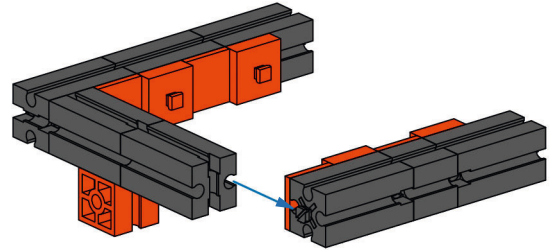
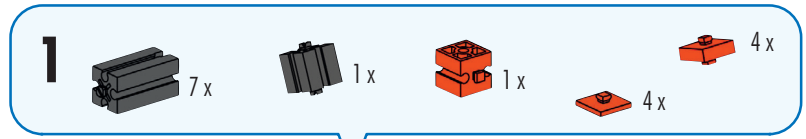

4

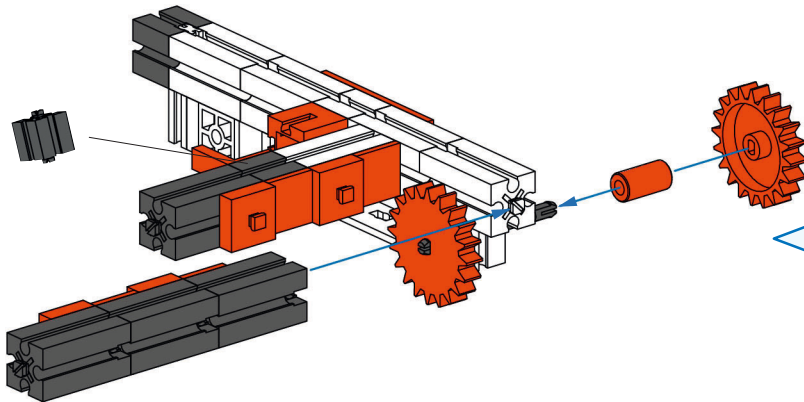
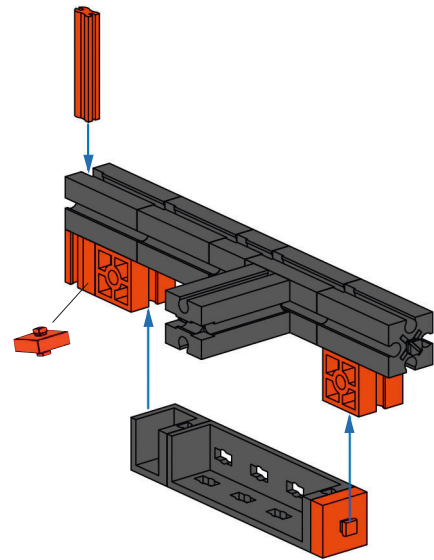
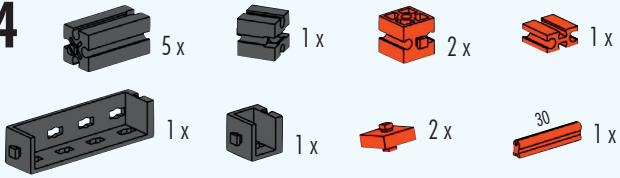

5

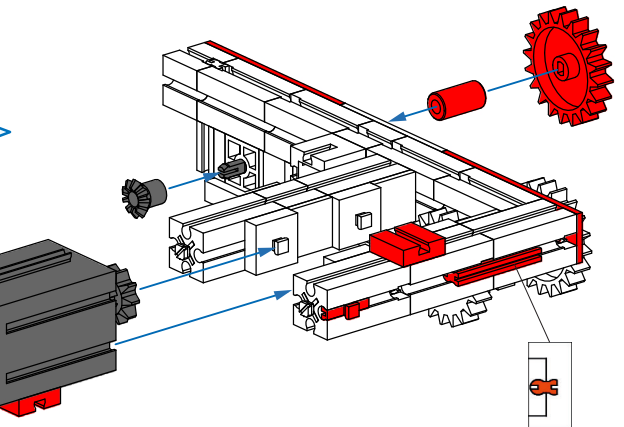
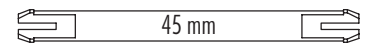
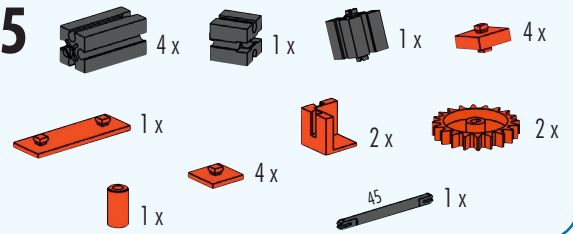

6

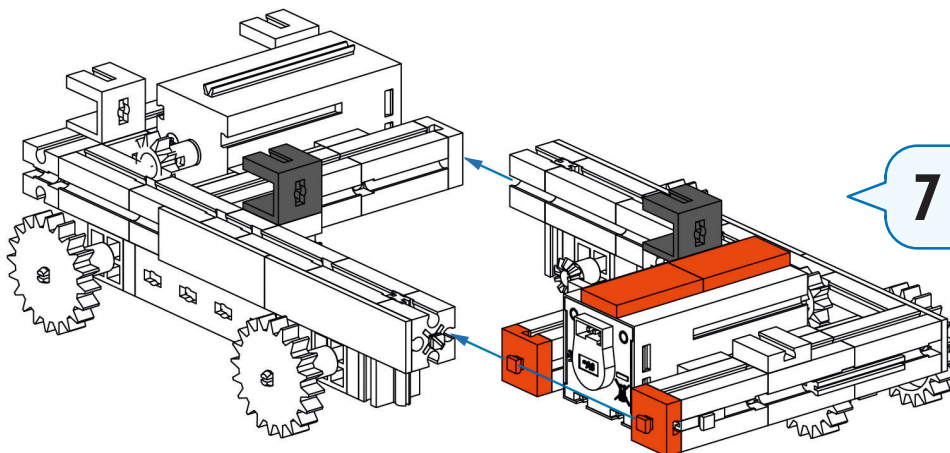
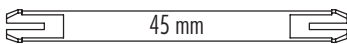
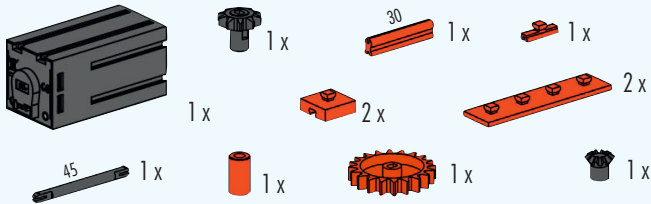

7



8

- 30 1x
- 1x
- 1x
- 1x

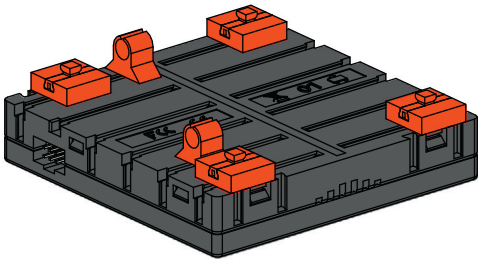
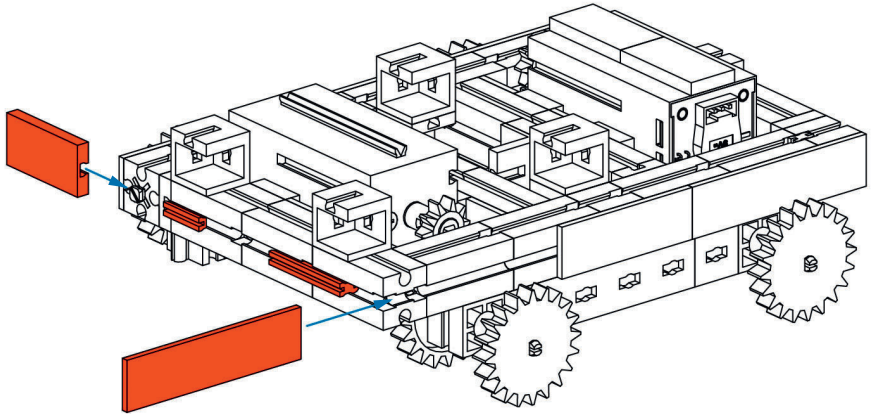

9

- 4x
- 1x
- 4x
- 2x

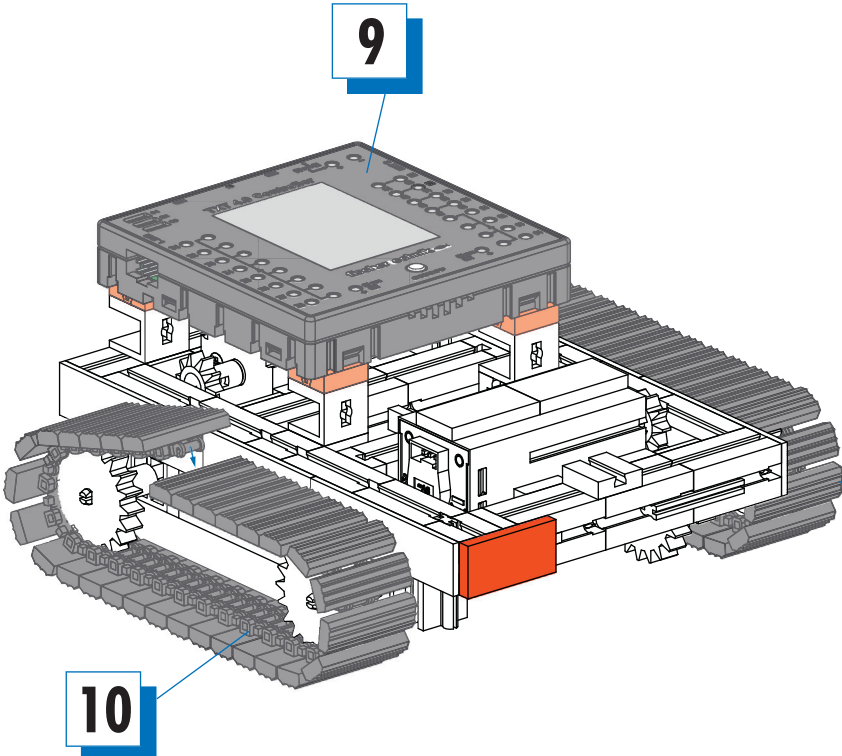
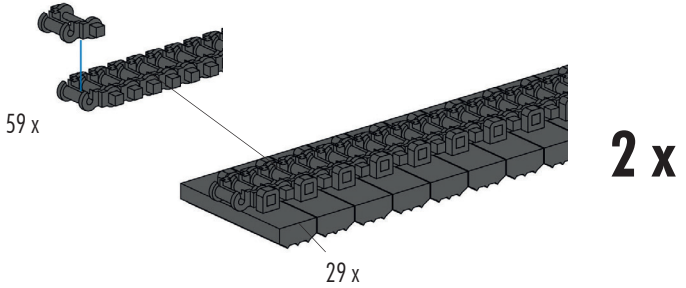

10

- 118x
- 58x





11

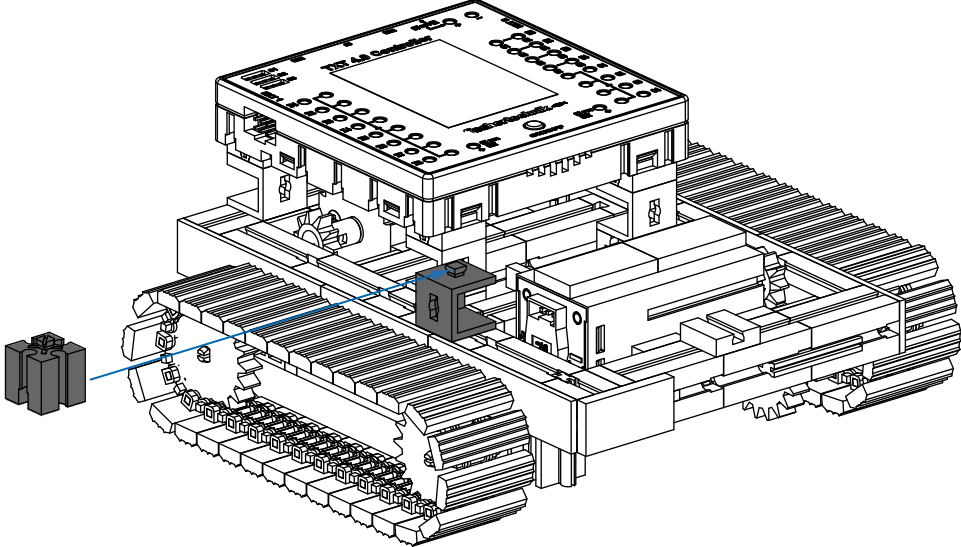

- 1x

12  1x  1x



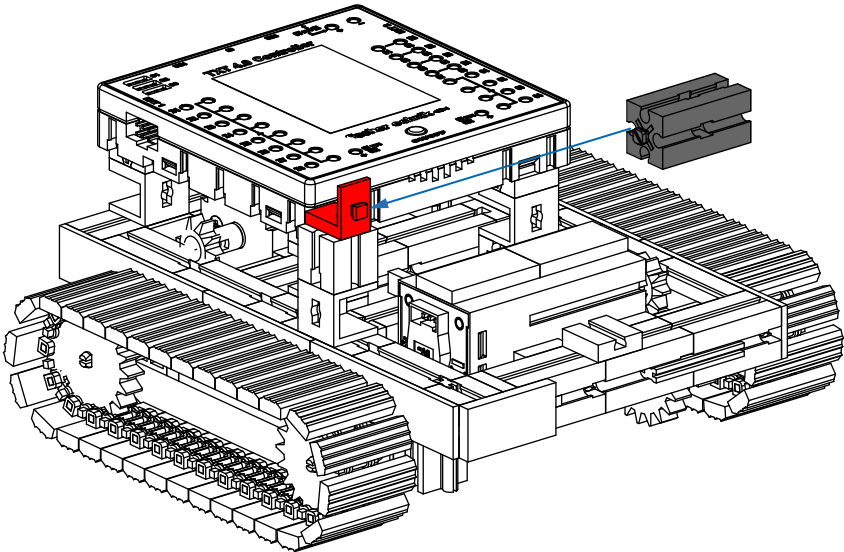

13  1x  1x

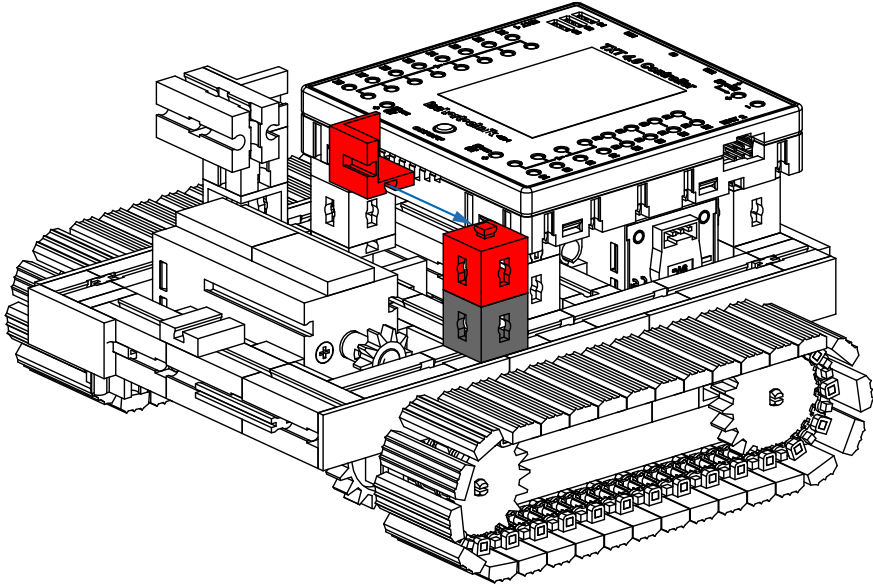

14  1x  1x  1x



15  1x  1x

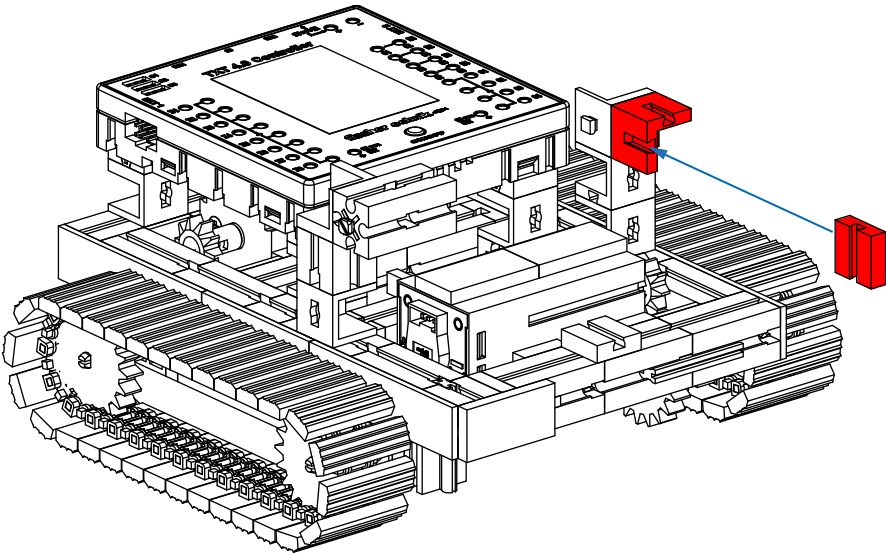

16

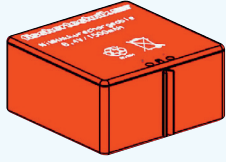

1 x

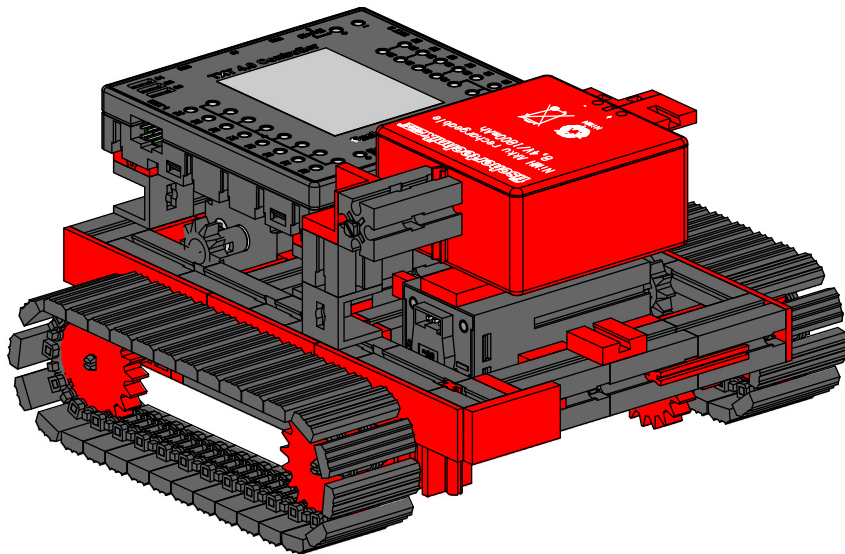
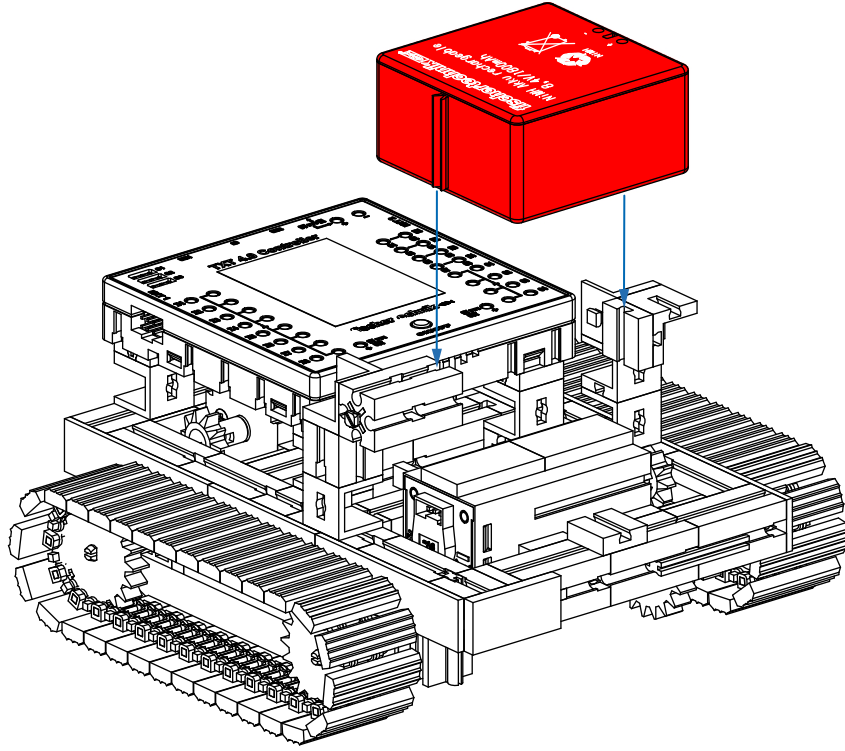

Robotics Add On: Competition Set

fischertechnik GmbH
Klaus-Fischer-Str. 1
72178 Waldachtal
Germany
Phone: +49 74 43/12-43 69
Fax: +49 74 43/12-45 91
info@fischertechnik.de
www.fischertechnik.de

