

Class Set Gears

Bauanleitung
Assembly instruction
Instructions de montage
Bouwhandleiding
Instrucciones de construcción
Manual de montagem
Istruzioni di montaggio
Инструкция по сборке
安装说明书

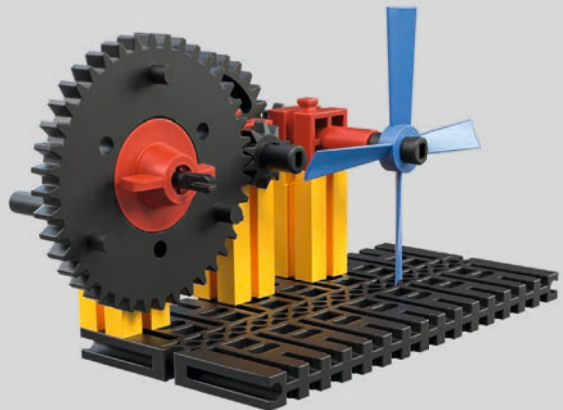

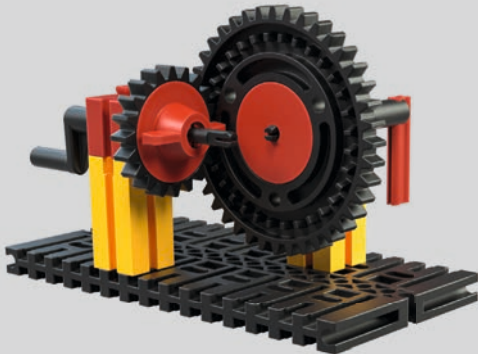
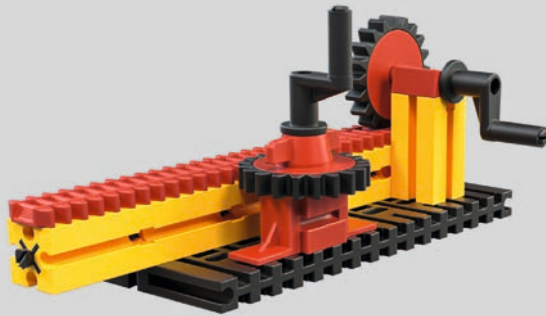

- Auf dem fischertechnik eLearning Portal bieten wir Ihnen die Möglichkeit, noch mehr Hintergrundwissen zum Thema des Baukastens zu erhalten und sich umfangreiche didaktische Begleitmaterialien für den Einsatz im Unterricht herunterzuladen. Über **www.fischertechnik-elearning.com** gelangen Sie direkt zum eLearning Portal.
- On the fischertechnik eLearning portal, we offer you the opportunity to obtain even more background knowledge on the subject of the construction kit and to download extensive didactic accompanying materials for use in the classroom. You can access the eLearning portal directly via **www.fischertechnik-elearning.com**.
- Avec le portail eLearning de fischertechnik, vous pouvez parfaire vos connaissances au sujet de la boîte de construction. Cliquez sur **www.fischertechnik-elearning.com** pour accéder directement à notre portail.
- Met het fischertechnik eLearning portaal geven wij u de mogelijkheid, nog meer achtergrondkennis over het thema van het modulaire systeem te verkrijgen. Via **www.fischertechnik-elearning.com** komt u direct bij het eLearning portaal.
- En el portal de eLearning de fischertechnik te ofrecemos la posibilidad de obtener aún más conocimientos de fondo sobre el tema del kit de construcción y de descargar amplios materiales didácticos de acompañamiento para utilizar en el aula. A través de **www.fischertechnik-elearning.com** podrá acceder directamente al portal de aprendizaje electrónico.
- Com o portal de eLearning da fischertechnik damos lhe a possibilidade de obter ainda mais conhecimentos aprofundados sobre os kits de construção. Em **www.fischertechnik-elearning.com** pode aceder diretamente ao portal de eLearning.
- Con il portale eLearning di fischertechnik vi diamo la possibilità di accumulare maggiori informazioni di base sul tema delle scatole di montaggio. Tramite **www.fischertechnik-elearning.com** potete raggiungere direttamente il portale eLearning.
- Обучающий Интернет-портал компании fischertechnik предлагает вам возможность получить больше базовых знаний по теме конструирования. По ссылке **www.fischertechnik-elearning.com** вы попадаете прямо на обучающий Интернет-портал.
- 通过 fischertechnik eLearning 电子学习门户网站，我们为您提供更多关于积木的背景知识。登陆 **www.fischertechnik-elearning.com** 访问我们的 eLearning 门户网站。

Inhalt
Contents
Contenu

Inhoud
Contenido
Conteúdo

Contenuto
Содержание
目录

Einzelteilübersicht / Spare parts list / Liste des pièces détachées / Onderdelenoverzicht / Lista da piezas / Resumo de peça individual / Singoli componenti / Перечень деталей / 零件概览 3

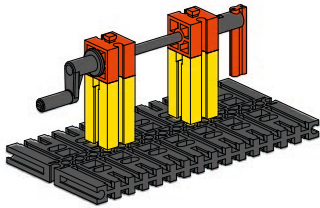

Antriebswelle / Drive shaft / Arbre de transmission / Aandrijf-as / Eje de transmisión / Eixo de transmissão / Albergo di trasmissione / Приводной вал / 传动轴 5

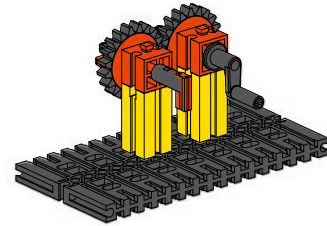

Zahnradgetriebe 1:1 / Gear transmission 1:1 / Transmission 1:1 / Versnellingsbak 1:1 / Transmisión de engranajes 1:1 / Transmissão de velocidades 1:1 / Trasmisione a ingranaggi 1:1 / Редукторная передача 1:1 / 齿轮传动1:1 6

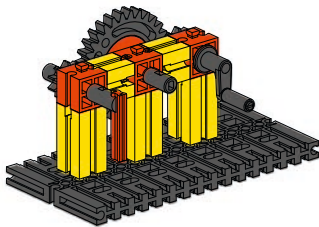

Zahnradgetriebe 1:1 ohne Richtungsänderung / Gear transmission 1:1 without change of direction / Transmission 1:1 sans changement de direction / Overbrenging 1:1 zonder verandering van richting / Transmisión de marchas 1:1 sin cambio de dirección / Transmissão de engrenagens 1:1 sem mudança de direcção / Trasmisione del cambio 1:1 senza cambio di direzione / Редукторная передача 1:1 без изменения направления движения / 齿轮传动1:1不改变方向 7

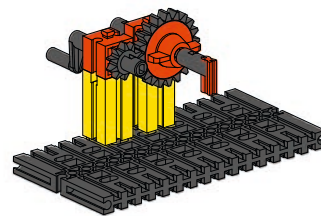

Zahnradgetriebe 2:1 / Gear transmission 2:1 / Transmission 2:1 / Versnellingsbak 2:1 / Transmisión de engranajes 2:1 / Transmissão de velocidades 2:1 / Trasmisione a ingranaggi 2:1 / Редукторная передача 2:1 / 齿轮传动2:1 8

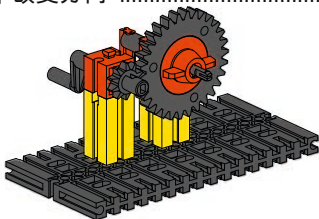

Zahnradgetriebe 3:1 / Gear transmission 3:1 / Transmission 3:1 / Versnellingsbak 3:1 / Transmisión de engranajes 3:1 / Transmissão de velocidades 3:1 / Trasmisione a ingranaggi 3:1 / Редукторная передача 3:1 / 齿轮传动3:1 9

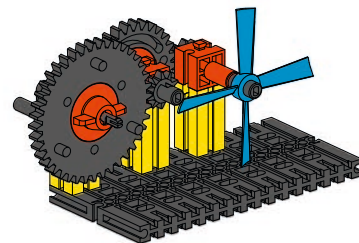

Zahnradgetriebe 1:12 / Gear transmission 1:12 / Transmission 1:12 / Versnellingsbak 1:12 / Transmisión de engranajes 1:12 / Transmissão de velocidades 1:12 / Trasmisione a ingranaggi 1:12 / Редукторная передача 1:12 / 齿轮传动1:12 10

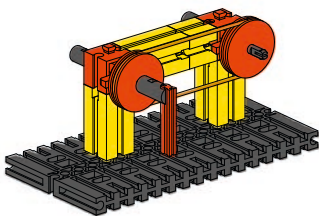

Riemengetriebe 1:1 / Belt drive 1:1 / Entraînement par courroie 1:1 / Riemaandrijving 1:1 / Transmisión por correa 1:1 / Condução de cinto 1:1 / Trasmisione a cinghia 1:1 / Ременный привод 1:1 / 皮带传动1:1 12

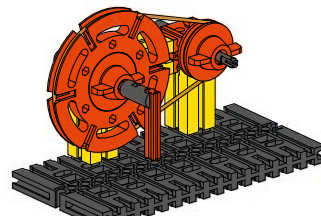

Riemengetriebe 2:1 / Belt drive 2:1 / Entraînement par courroie 2:1 / Riemaandrijving 2:1 / Transmisión por correa 2:1 / Condução de cinto 2:1 / Trasmisione a cinghia 2:1 / Ременный привод 2:1 / 皮带传动2:1 13

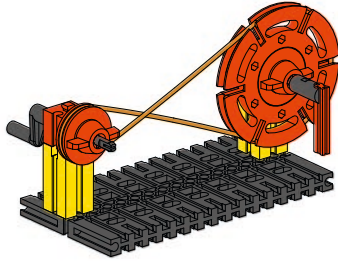

Riemengetriebe 2:1 mit Richtungsänderung / Belt drive 2:1 with change of direction / Transmission par courroie 2:1 avec changement de direction / Riemoverbrenging 2:1 met verandering van richting / Transmisión por correa 2:1 con cambio de dirección / Transmissão de correia 2:1 com mudança de direção / Trasmissione a cinghia 2:1 con cambio di direzione / Ременная передача 2:1 со сменой направления движения / 皮带传动2:1，可改变方向 14

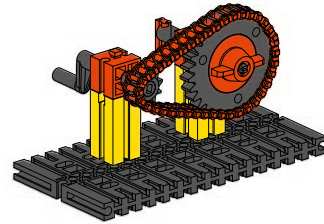

Kettengetriebe 3:1 / Chain gear 3:1 / Engrenage à chaîne 3:1 / Kettingoverbrenging 3:1 / Cadena de engranajes 3:1 / Engrenagem de corrente 3:1 / Ingranaggio a catena 3:1 / Цепная передача 3:1 / 链条齿轮3:1 15

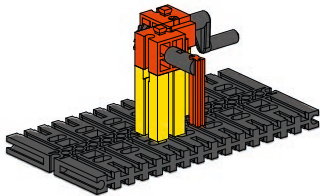

Kegelzahnradgetriebe / Bevel gearbox / Boîte à engrenages coniques / Kegelwielversnellingsbak / Caja de engranajes cónicos / Caixa de engrenagem biselada / Riduttore a ingranaggi conici / Коническая коробка передач / 锥齿轮箱 16

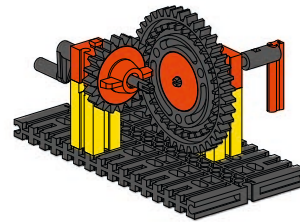

Kronradgetriebe / Crown gear / Couronne dentée / Kroonuitrusting / Engrenaje de la corona / Equipamento da coroa / Ingranaggio della corona / Заводная шестерня / 皇冠齿轮 17

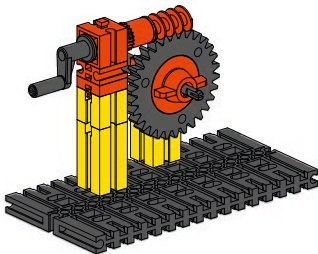

Schneckengetriebe / Worm gear / Engrenage à vis sans fin / Wormwiel / Engrenaje de tornillo sin fin / Equipamento para minhocas / Ingranaggio a vite senza fine / Червячный редуктор / 蜗轮蜗杆 18

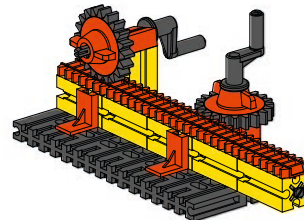



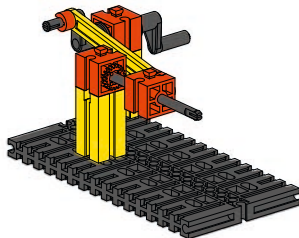











Zahnstangengetriebe / Rack and pinion gear / Boîte de vitesses à pignon et crémaillère / Tandheugel en rondsel versnellingsbak / Caja de cambios de cremallera / Caixas de velocidades de cremalheira e pinhão / Caixas de velocidades de cremalheira e pinhão / Коробка передач стойки и шестерни / 齿轮齿条式变速箱 19



Schubkurbel / Push crank / Poussez la manivelle / Duw slinger / Manivela de empuje / Manivela de empurrar / Spingere la manovella / Пуш-шатуn / 推曲柄 21













Einzelteilübersicht
Spare parts list
Liste des pièces détachées

	31 019 1 x
	31 021 2 x
	31 022 1 x
	31 053 2 x
	31 054 1 x
	31 058 3 x
	31 060 1 x
	31 061 1 x
	31 597 1 x
	31 848 1 x
	31 915 1 x
	31 981 1 x
	31 982 2 x
	31 983 1 x

Onderdelenoverzicht
Lista da piezas
Resumo de peça individual

	32 064 3 x
	35 031 3 x
	35 061 2 x
	35 063 2 x
	35 064 3 x
	35 073 1 x
	35 087 1 x
	35 088 2 x
	35 129 1 x
	35 945 2 x
	36 227 1 x
	36 248 40 x
	36 264 1 x
	36 326 1 x

Singoli componenti
Перечень деталей
零件概览

	36 334 1 x
	36 337 1 x
	36 819 2 x
	36 981 1 x
	37 237 1 x
	37 468 1 x
	37 679 1 x
	37 858 1 x
	38 423 4 x
	136 528 6 x
	136 529 2 x
	137 103 1 x

Sicherheitshinweise

Safety Information

Consignes de sécurité

Veiligheidsrichtlijnen

Indicaciones de seguridad

Observações sobre segurança

Informazioni per la sicurezza

Указания по технике безопасности

安全指南

- Achtung! Verletzungsgefahr an Bauteilen mit funktionsbedingten scharfen Kanten und Spitzen!
- Caution! Be careful not to hurt yourself on components with sharp or pointed edges!
- Attention! Risque de blessure sur les éléments comportant des arêtes et o pointes vives indispensables au bon fonctionnement!
- Let op! U kunt zich bezeren aan bouwstenen met scherpe randen of punten!
- Attenzione! Esiste il pericolo di lesione con i pezzi di costruzione che hanno bordi e punte spigolosi necessari per la funzionalità del pezzo!
- Atenção! Perigo de ferimentos em peças componentes com cantos vivos e pontas obrigatórios para o funcionamento !
- Attenzione! Pericolo di lesioni dovute a componenti con spigoli vivi e punte per motivi funzionali!
- Будьте осторожны! Об острые края деталей и и наконечники можно порезаться!
- 注意！
因功能需要而带有锋利的棱边和尖角的部件可能会带来受伤危险！

- Alle Einzelteile, insbesondere bewegliche Teile sind falls notwendig zu warten und zu reinigen.
- All components, especially moving parts, should be maintained and cleaned as necessary.
- Toutes les pièces détachées et en particulier les pièces mobiles, sont, si nécessaire, à entretenir et à nettoyer.
- Alle onderdelen, vooral de bewegende delen, kunnen, indien noodzakelijk, onderhouden en gereinigd worden.
- Es necesario mantener limpio y en buen estado cada una de las piezas. Particularmente las piezas móviles.
- Todas as peças individuais, especialmente peças móveis, devem ser submetidas à manutenção e limpas se necessário.
- Se necessario, tutti i singoli componenti, soprattutto le parti mobili, si devono eventualmente sottoporre a manutenzione e pulizia.
- Все детали, особенно подвижные, требуют ухода и чистки.
- 必要时应保养和清洁所有零件，尤指运动部件。



Hinweise zum Umweltschutz / Instructions for Environmental Protection / Remarques de protection de l'environnement / Bescherming van het milieu / Notas con respecto a la protección del medio ambiente / Instruções para a proteção do meio ambiente / Indicazioni sulla tutela ambientale / Указания по охране окружающей среды / 有关环保的提示：

www.fischertechnik.de/environment

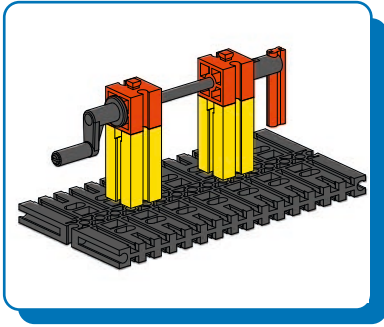

Antriebswelle
Drive shaft
Arbre de transmission

Aandrijfas
Eje de transmisión
Eixo de transmissão

Albero di trasmissione
Приводной вал
传动轴

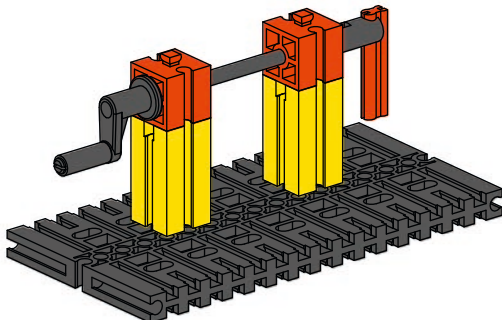
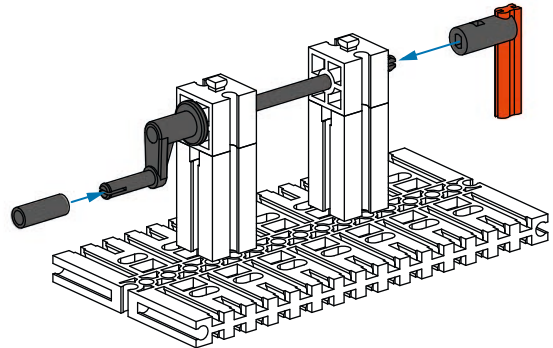
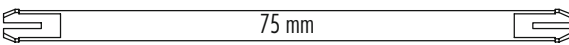
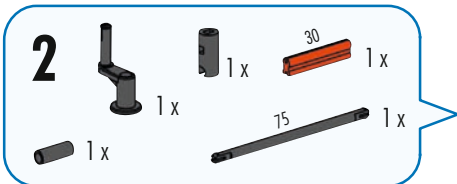
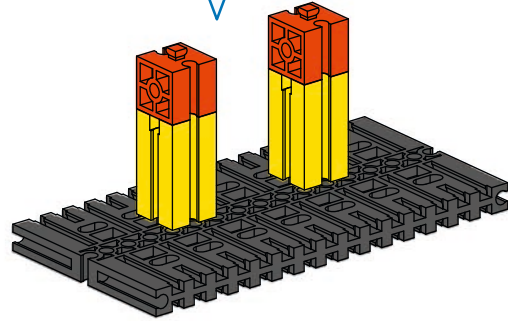
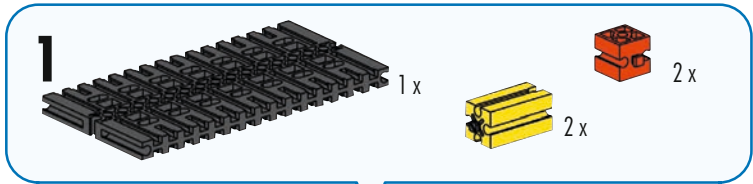

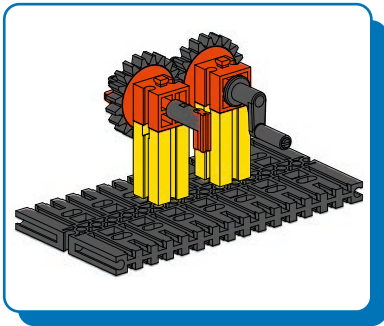

Zahnradgetriebe 1:1
 Gear transmission 1:1
 Transmission 1:1

Versnellingsbak 1:1

Transmisión de engranajes 1:1

Transmissão de velocidades 1:1

Trasmissione a ingranaggi 1:1

Редукторная передача 1:1

齿轮传动 1:1

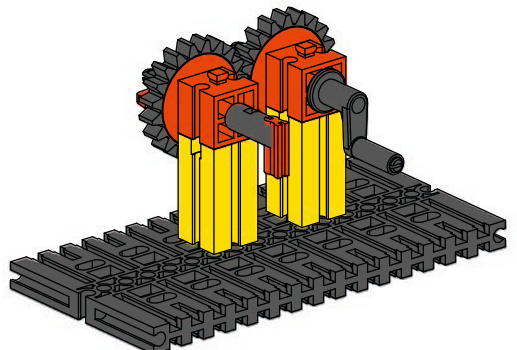
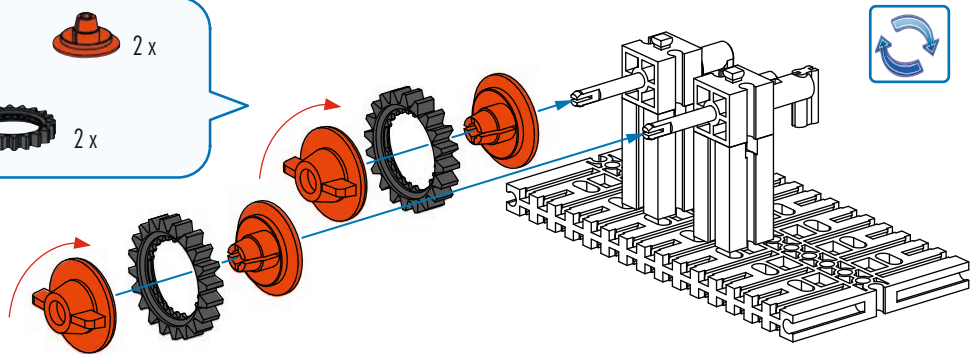
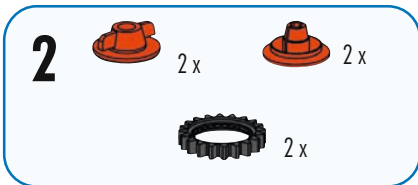
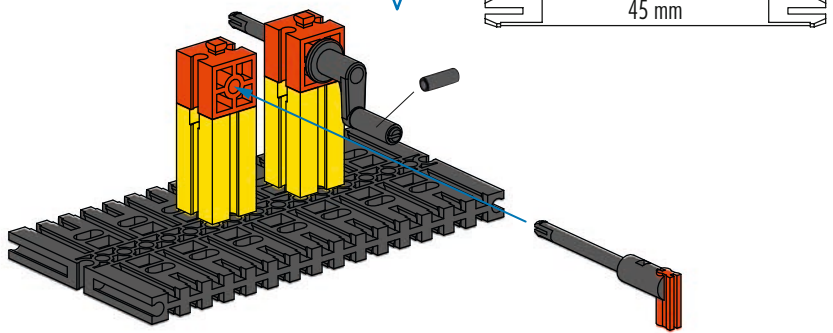
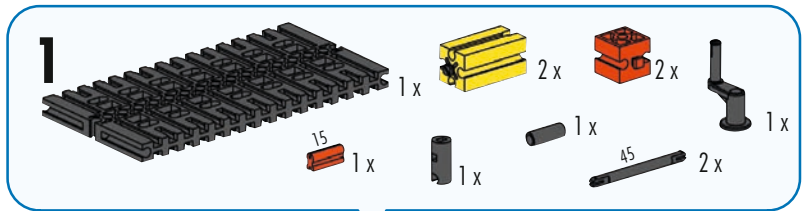

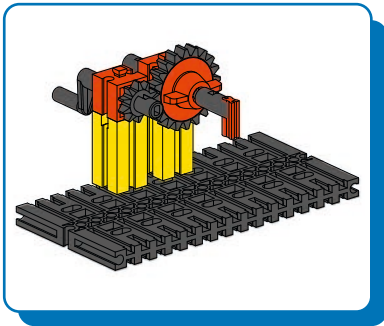

Zahnradgetriebe 2:1
 Gear transmission 2:1
 Transmission 2:1

Versnellingsbak 2:1

Transmisión de engranajes 2:1

Transmissão de velocidades 2:1

Trasmissione a ingranaggi 2:1

Редукторная передача 2:1

齿轮传动2:1

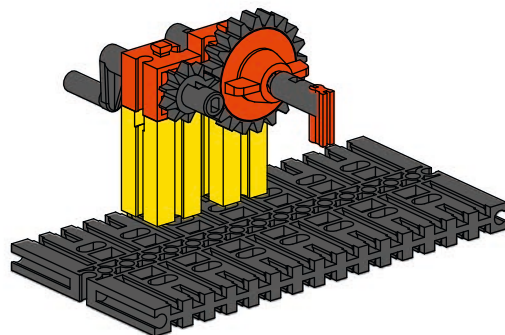
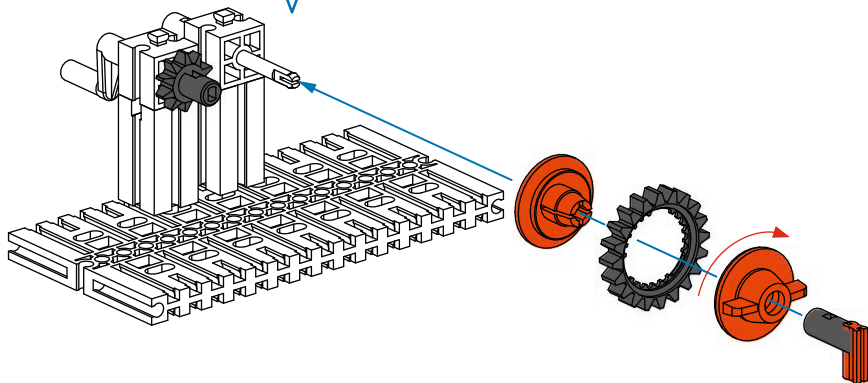
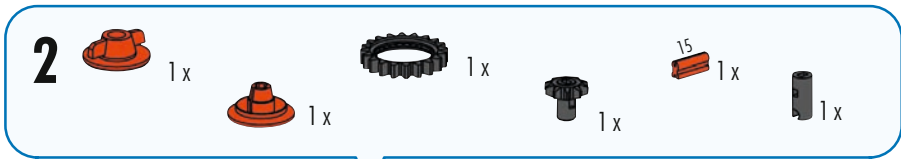
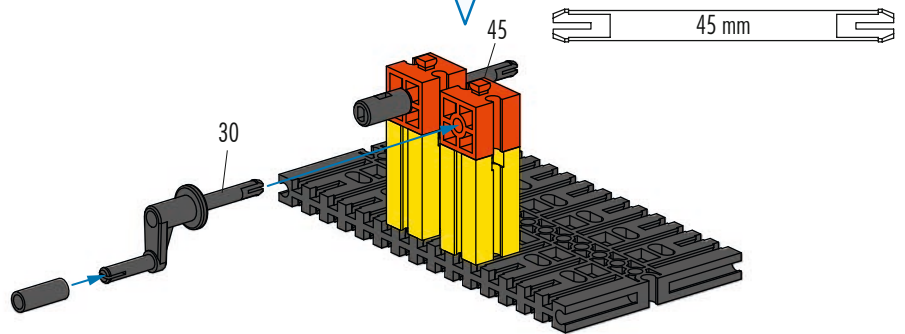
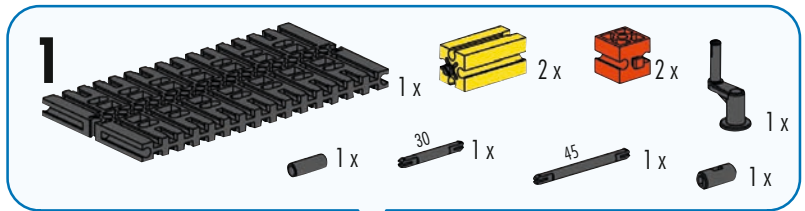

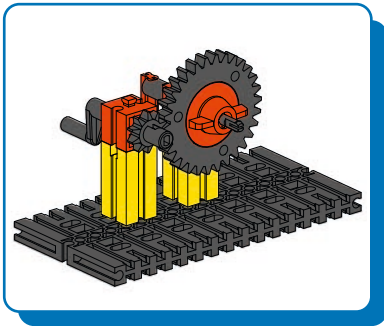

Zahnradgetriebe 3:1
Gear transmission 3:1
Transmission 3:1

Versnellingsbak 3:1
Transmisión de engranajes 3:1
Transmissão de velocidades 3:1

Trasmissione a ingranaggi 3:1
Редукторная передача 3:1
齿轮传动 3:1

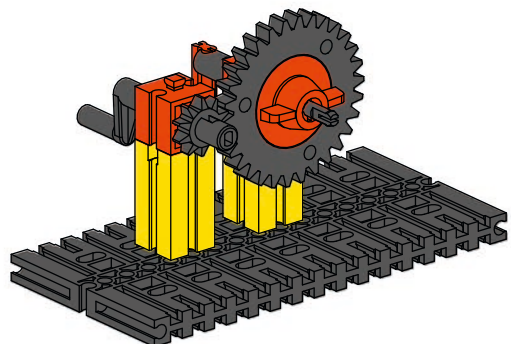
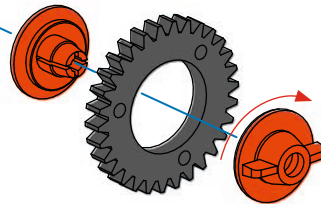
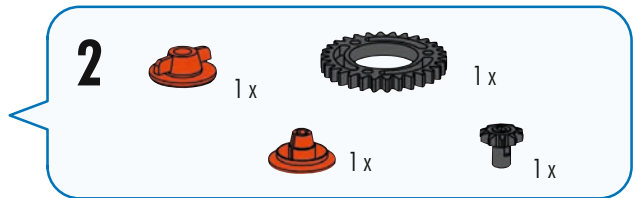
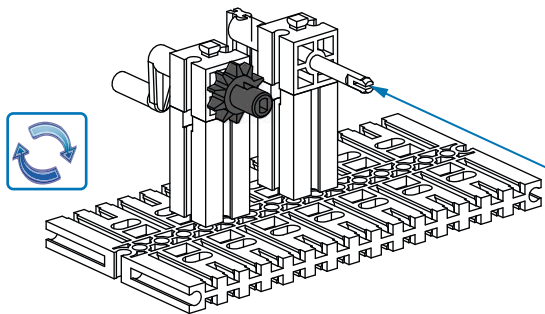
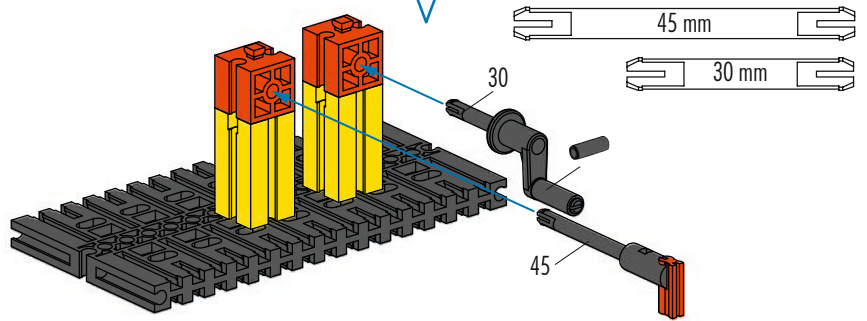
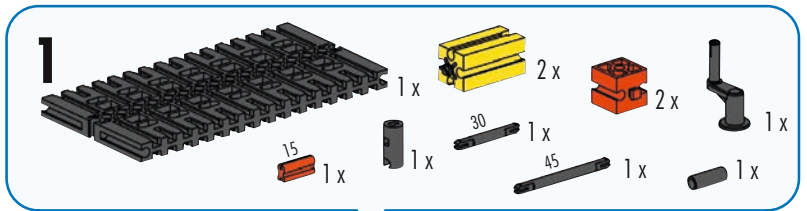

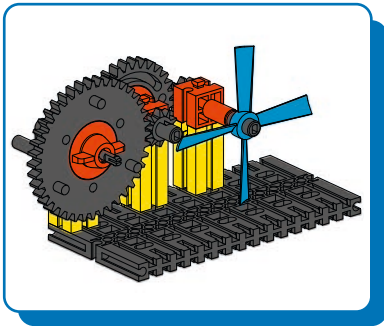

Zahnradgetriebe 1:12
 Gear transmission 1:12
 Transmission 1:12

Versnellingsbak 1:12
 Transmisión de engranajes 1:12
 Transmissão de velocidades 1:12

Trasmissione a ingranaggi 1:12
 Редукторная передача 1:12
 齿轮传动 1:12

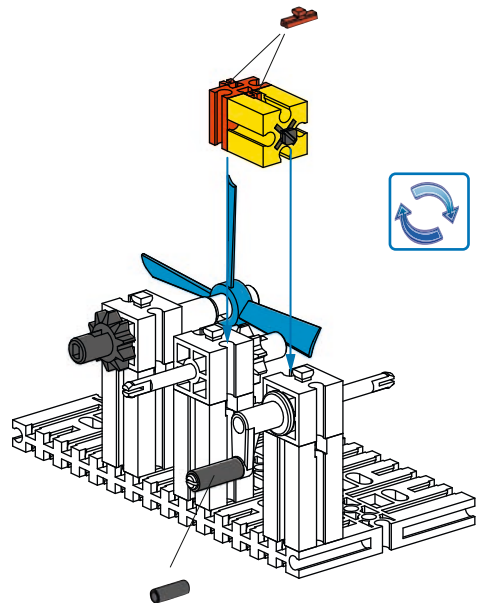
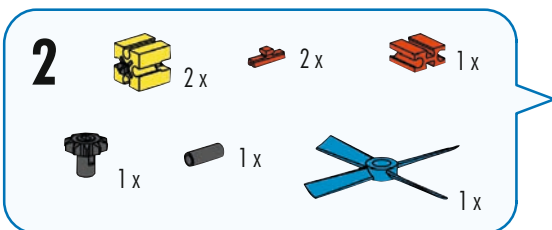
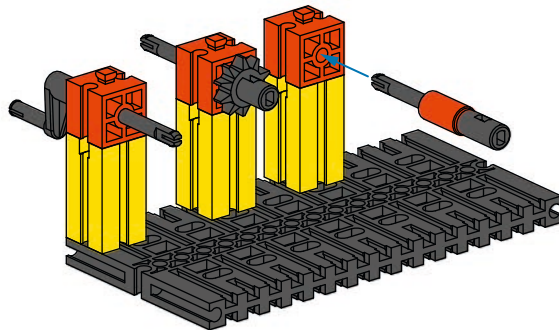
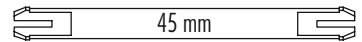
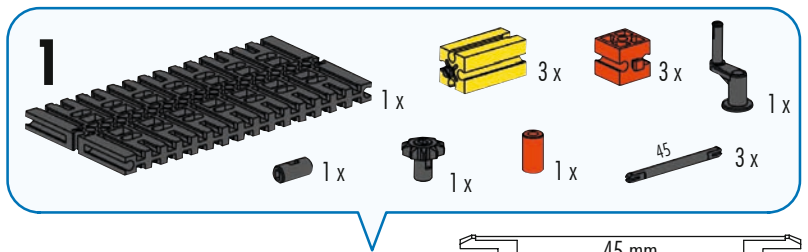

3

2x

1x

2x

1x

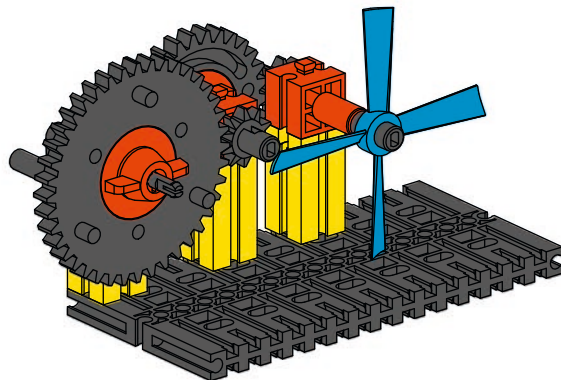
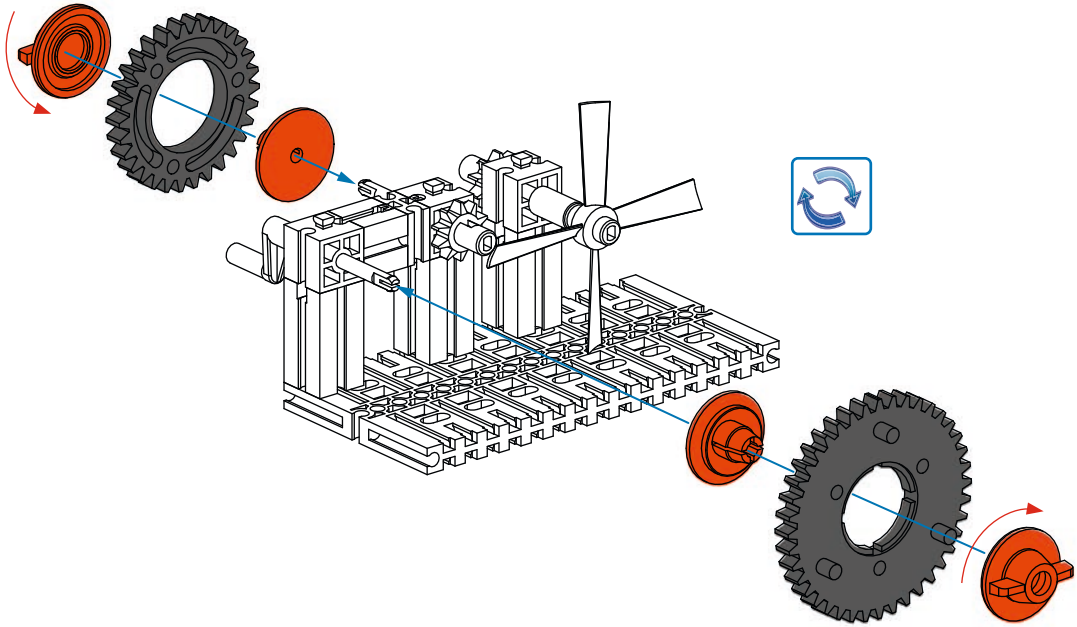

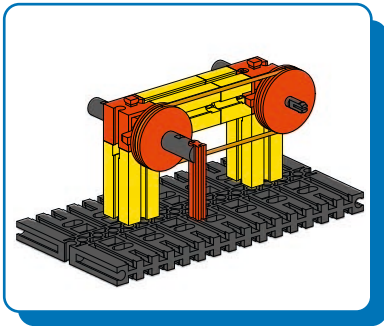

Riemengetriebe 1:1
Belt drive 1:1
Entraînement par courroie 1:1

Riemaandrijving 1:1
Transmisión por correa 1:1
Condução de cinto 1:1

Trasmissione a cinghia 1:1
Ременный привод 1:1
皮带传动 1:1

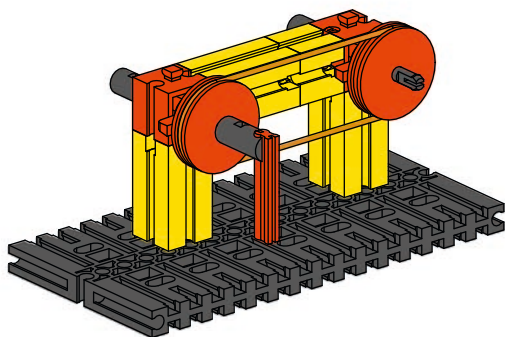
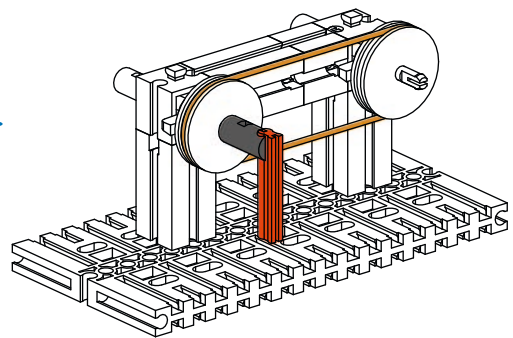
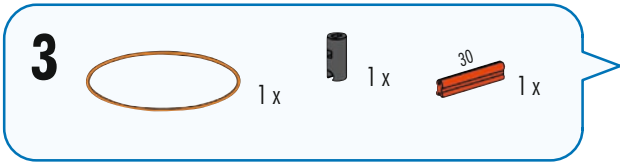
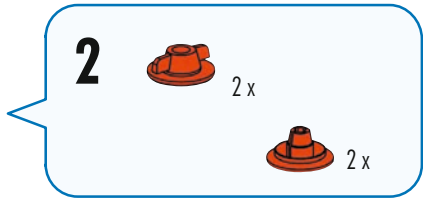
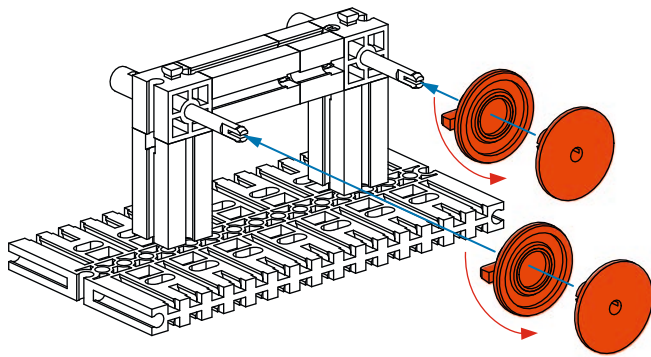
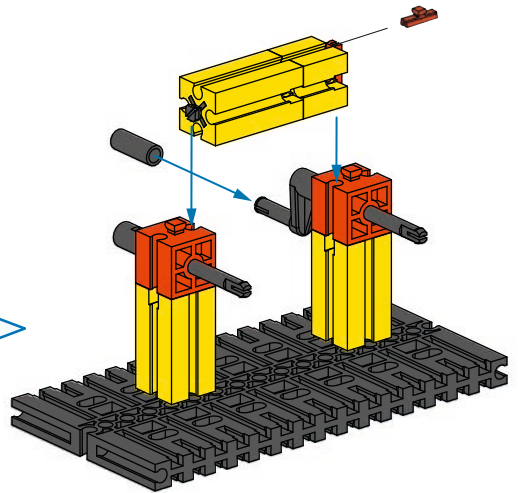
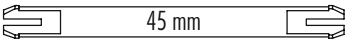
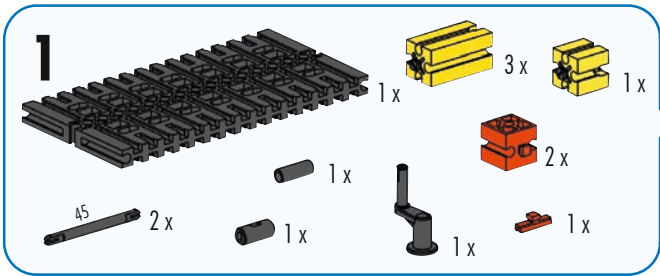

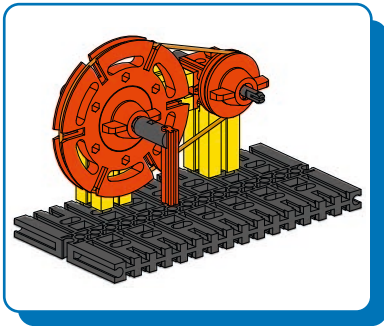

Riemengetriebe 2:1
Belt drive 2:1
Entraînement par courroie 2:1

Riemaandrijving 2:1
Transmisión por correa 2:1
Condução de cinto 2:1

Trasmissione a cinghia 2:1
Ременный привод 2:1
皮带传动 2:1

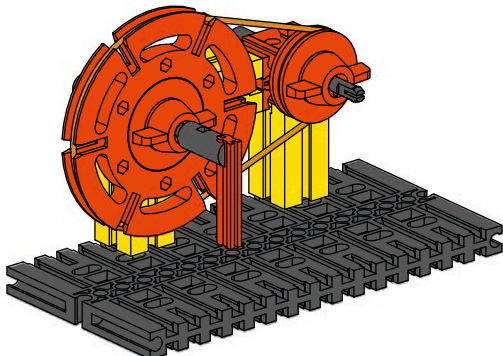
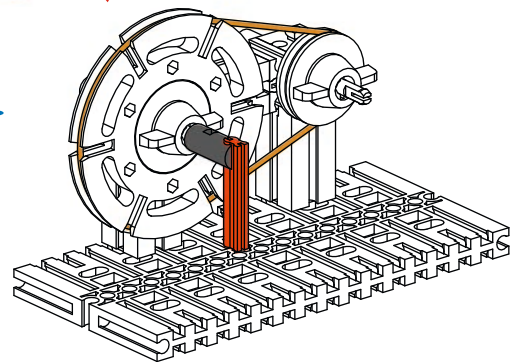
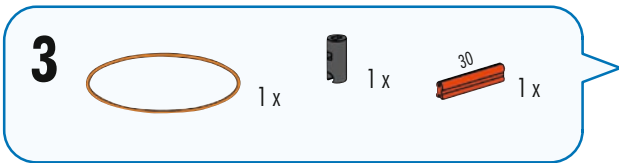
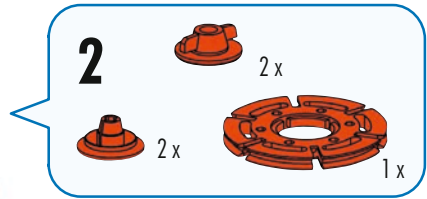
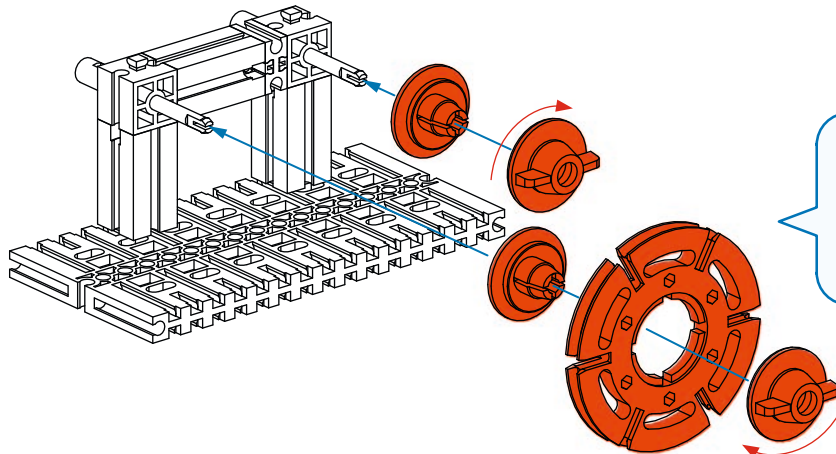
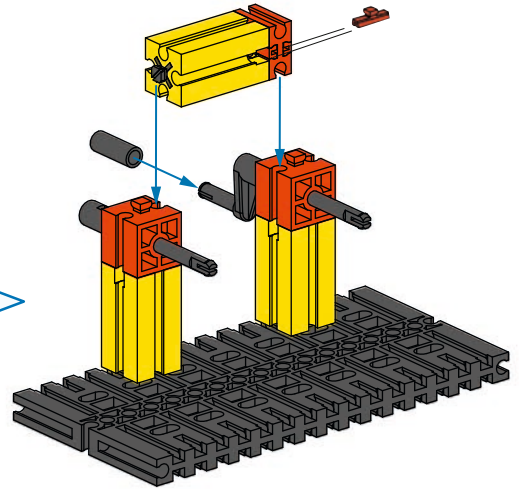
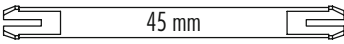
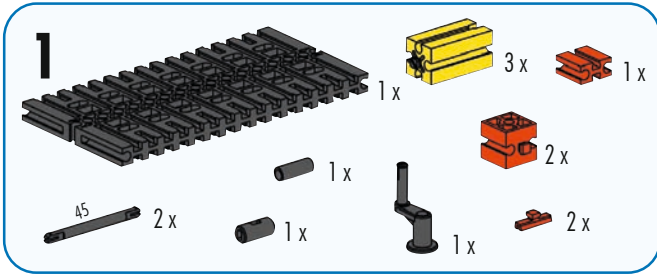

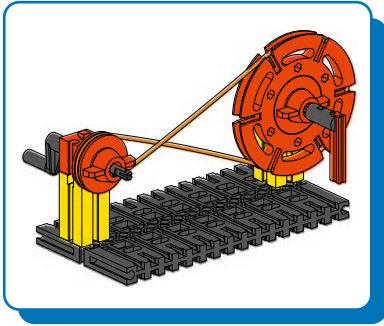

**Riemengetriebe 2:1 mit
Richtungsänderung**
Belt drive 2:1 with change
of direction
Transmission par courroie 2:1
avec changement de direction

**Riemoverbrenging 2:1 met
verandering van richting**
Transmisión por correa 2:1
con cambio de dirección
Transmissão de correia 2:1
com mudança de direção

**Trasmissione a cinghia 2:1
con cambio di direzione**
Ременная передача 2:1
со сменой направления
движения
皮带传动2:1, 可改变方向

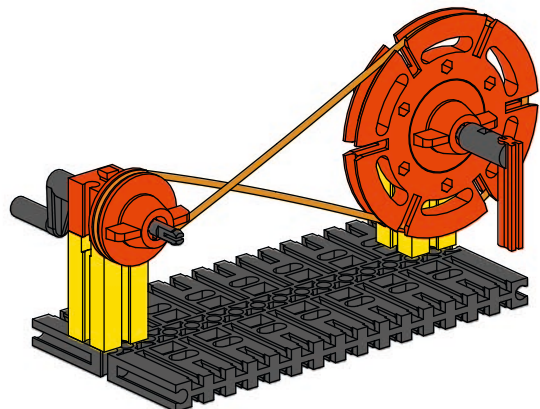
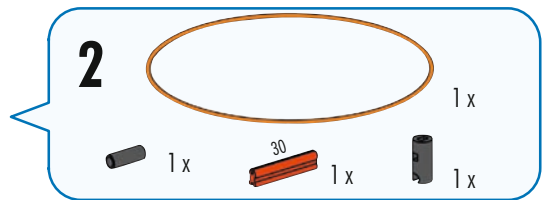
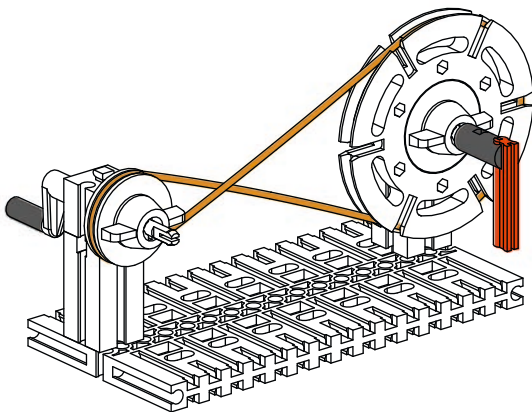
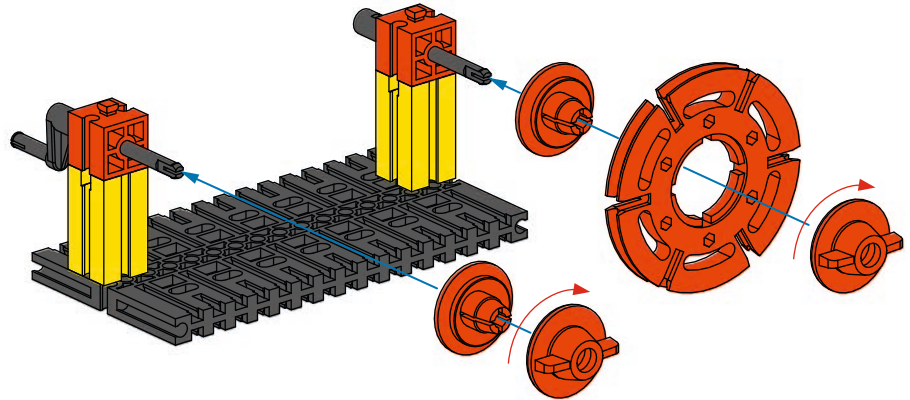
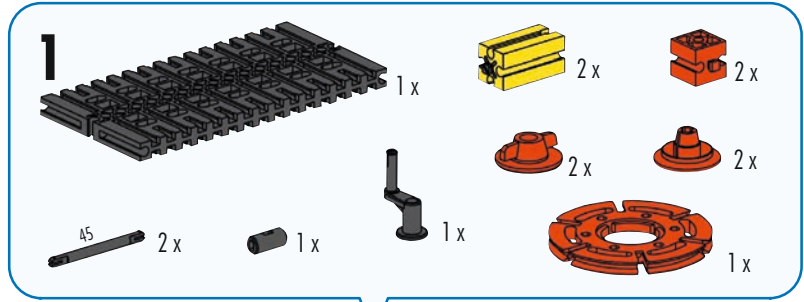

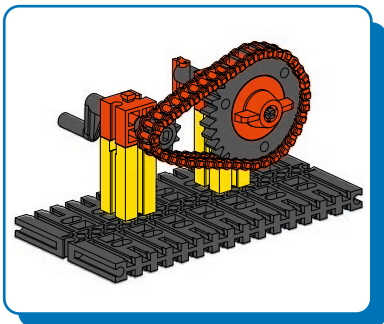

Kettengeräte 3:1
Chain gear 3:1
Engrenage à chaîne 3:1

Kettingoverbrenging 3:1
Cadena de engranajes 3:1
Engrenagem de corrente 3:1

Ingranaggio a catena 3:1
Цепная передача 3:1
链条齿轮 3:1

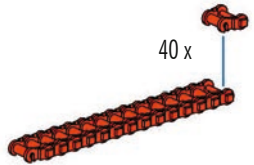
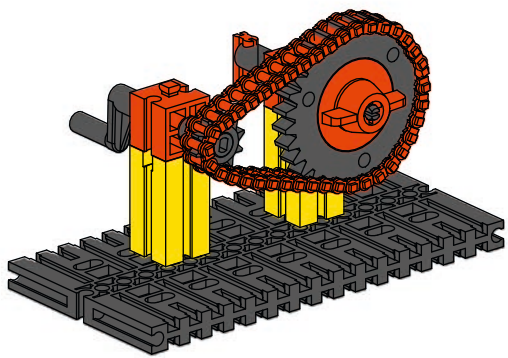
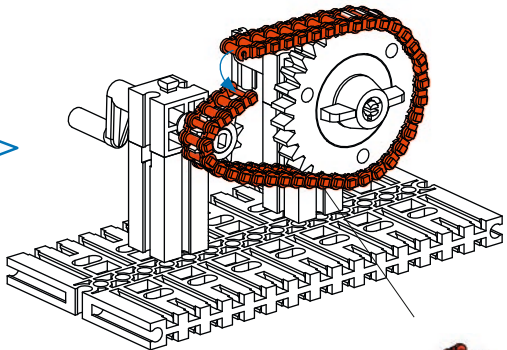
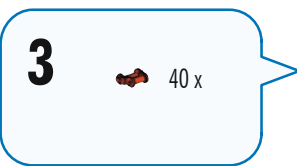
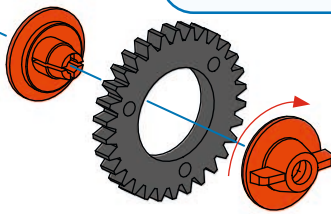
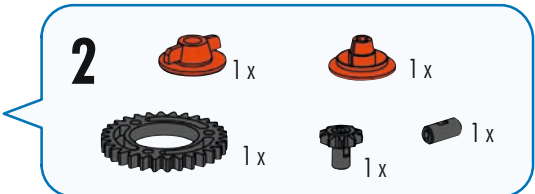
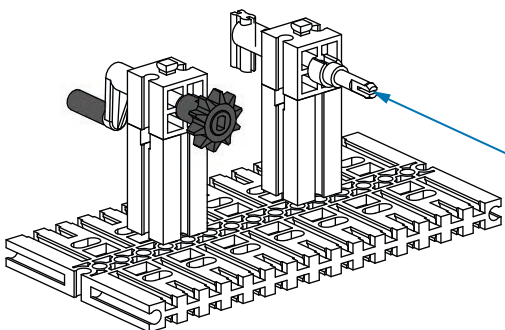
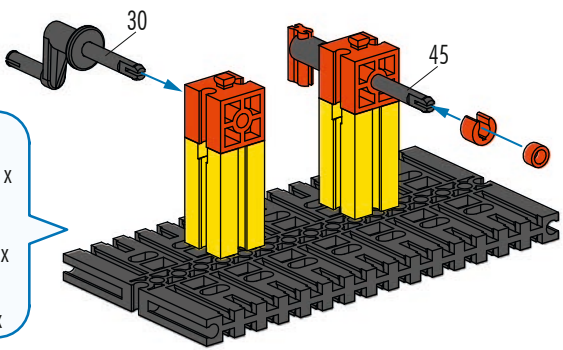
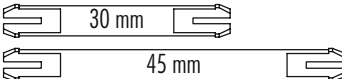
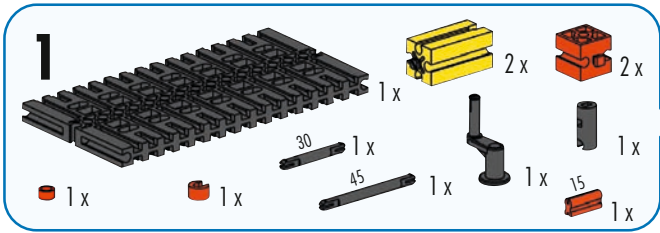

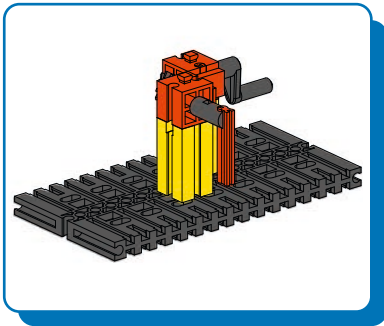

Kegelzahnradgetriebe
Bevel gearbox
Boîte à engrenages coniques

Kegelwielversnellingsbak
Caja de engranajes cónicos
Caixa de engrenagem biselada

Riduttore a ingranaggi conici
 Коническая коробка передач
 锥齿轮箱

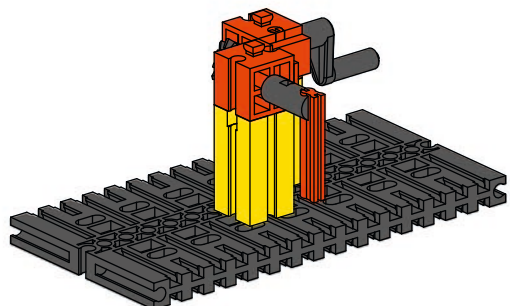
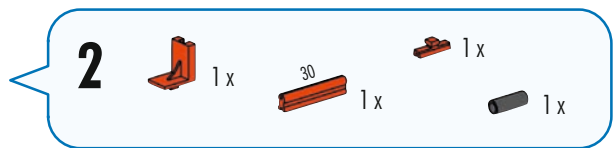
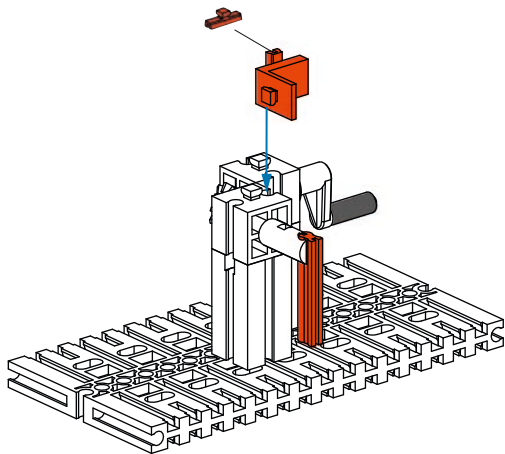
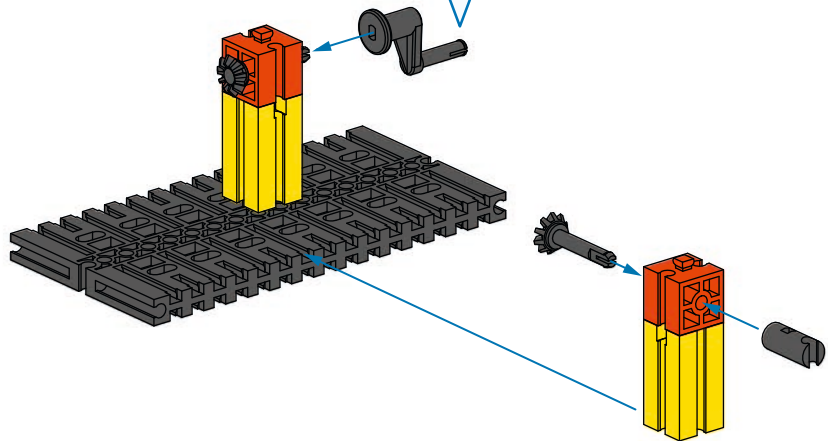
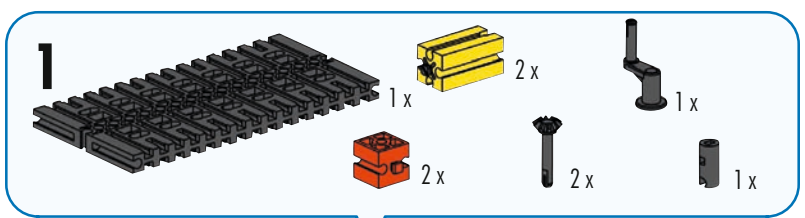

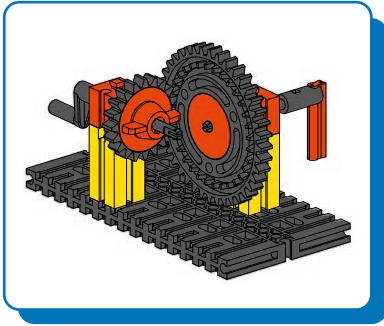

Kronradgetriebe
 Crown gear
 Couronne dentée

Kroonuitrusting
 Engranaje de la corona
 Equipamento da coroa

Ingranaggio della corona
 Заводная шестерня
 皇冠齿轮

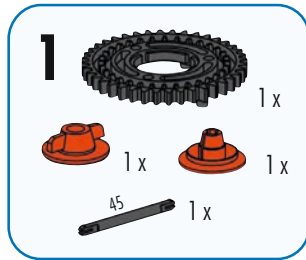

45 mm

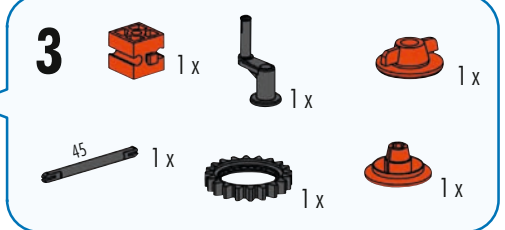
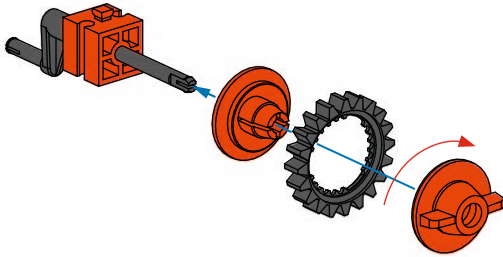
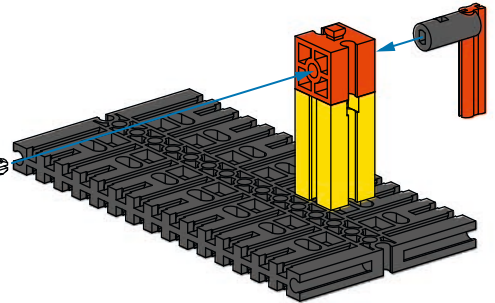
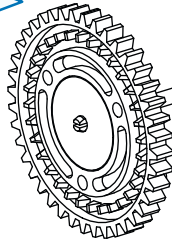
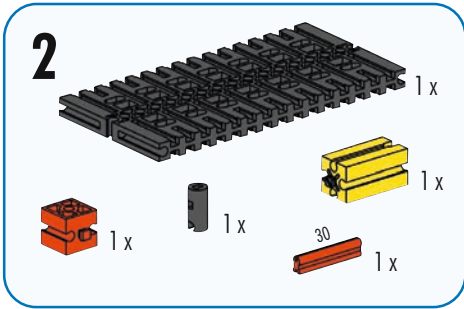
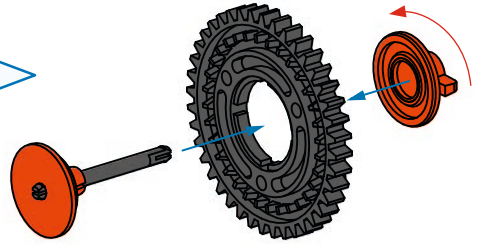

45 mm

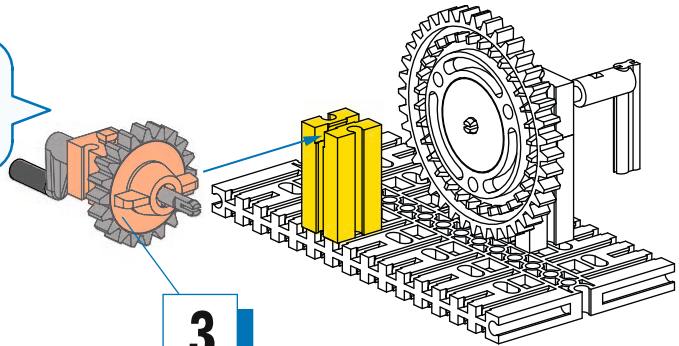
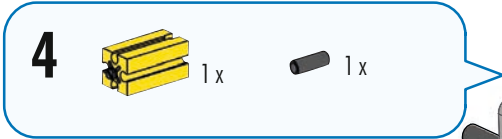

3

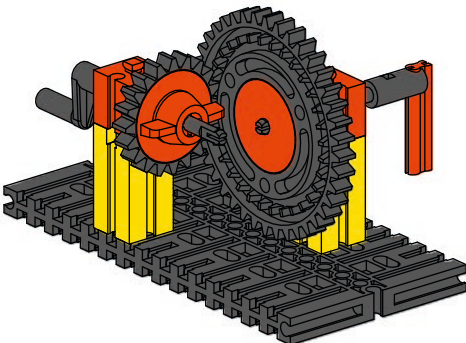

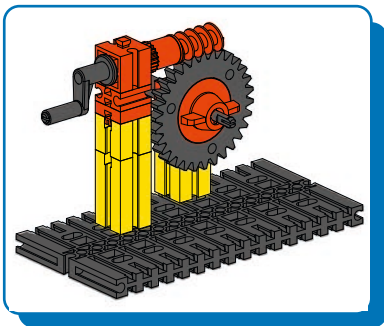

Schneckengetriebe
Worm gear
Engrenage à vis sans fin

Wormwiel
Engranaje de tornillo sin fin
Equipamento para minhocas

Ingranaggio a vite
senza fine
Червячный редуктор
蜗轮蜗杆

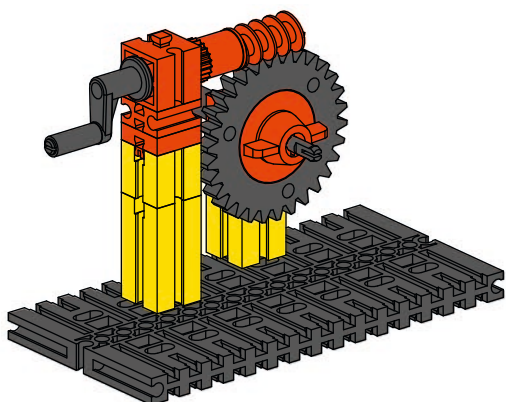
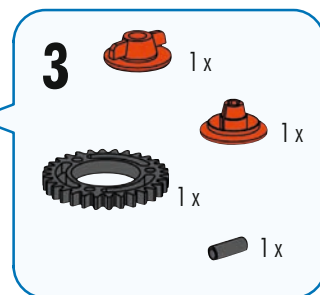
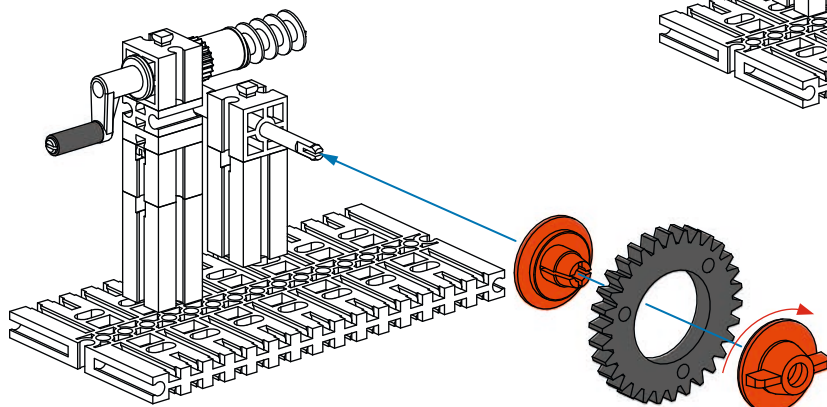
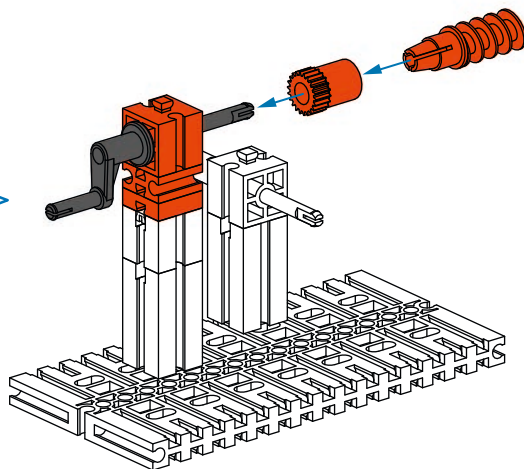
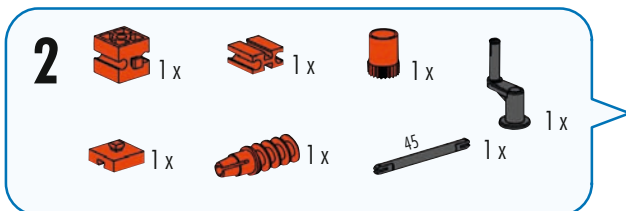
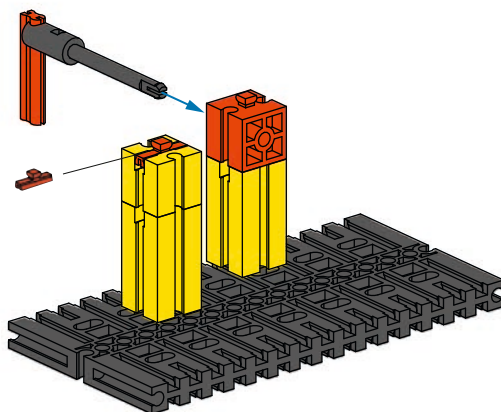
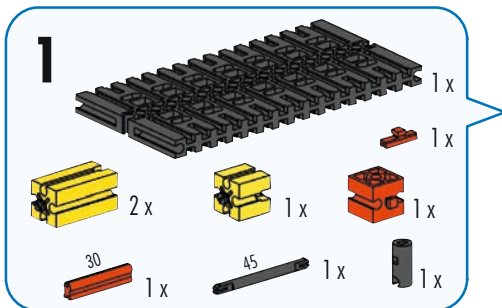

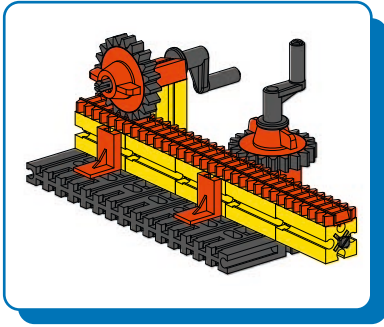

Zahnstangengetriebe
 Rack and pinion gear
 Boîte de vitesses à pignon et
 crémaillère

Tandheugel en rondsel
 versnellingsbak
 Caja de cambios de
 cremallera
 Caixas de velocidades de
 cremalheira e pinhão

Caixas de velocidades de
 cremalheira e pinhão
 Коробка передач стойки
 и шестерни
 齿轮齿条式变速箱

1

1 x 45 1 x 15° 1 x 1 x 1 x 2 x 1 x 1 x

45 mm

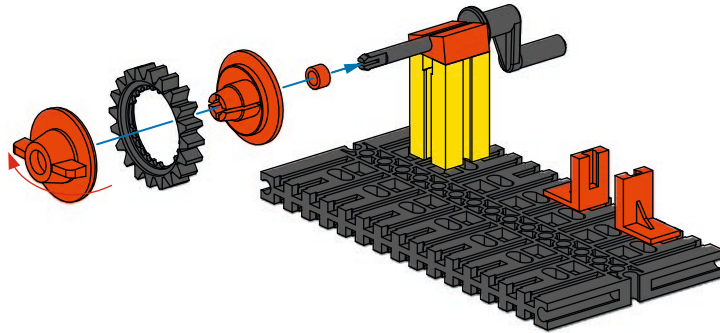

2

1 x 1 x 1 x 1 x 1 x

30 30 mm

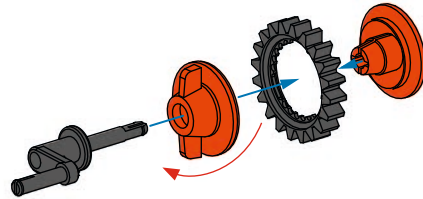

3

5 x 2 x 1 x

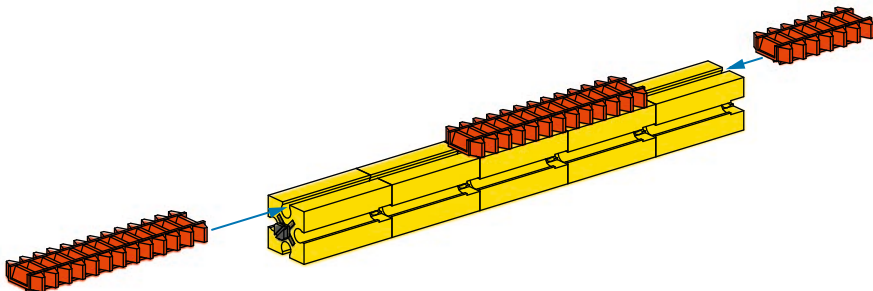

4  1x  1x  2x

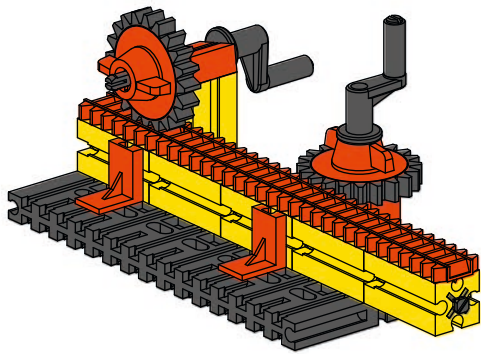
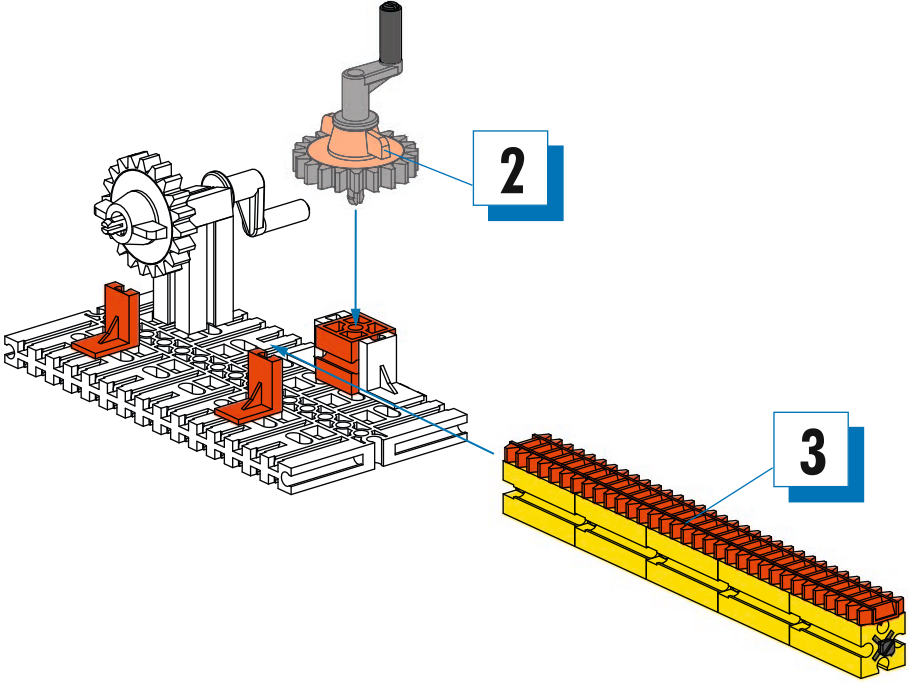

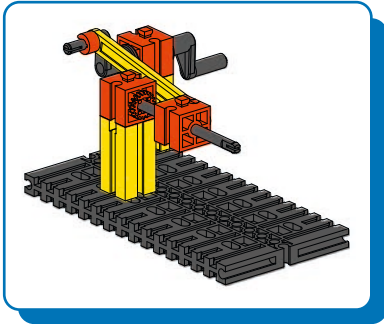

Schubkurbel
Push crank
Poussez la manivelle

Duw slinger
Manivela de empujeanivela
de empujar

Spingere la manovella
Пуш-шатун
推曲柄

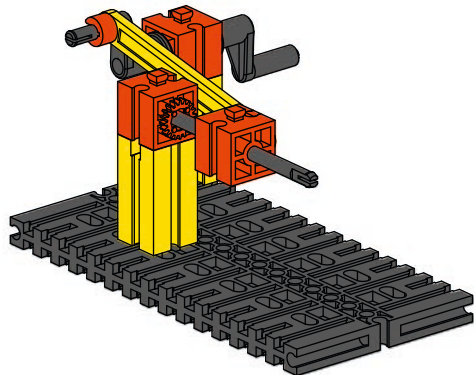
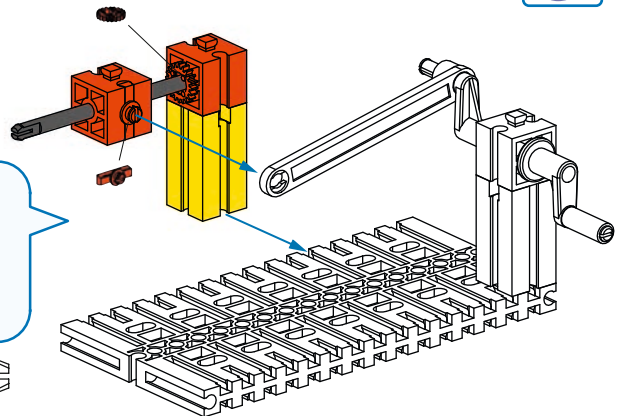
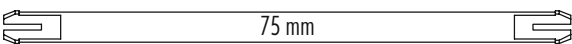
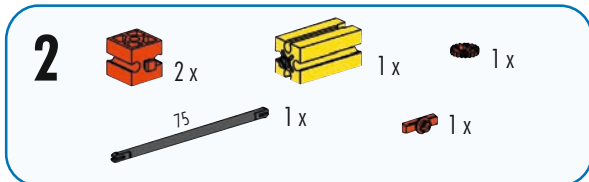
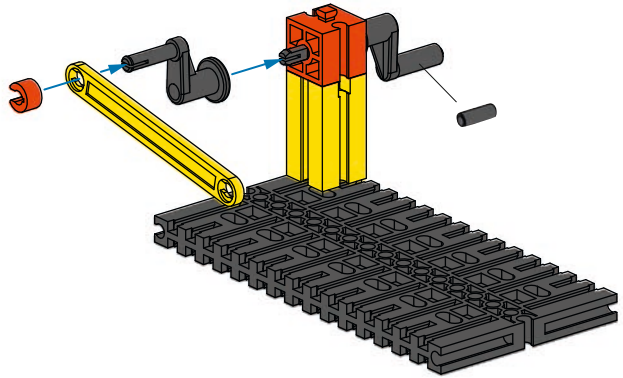
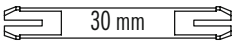
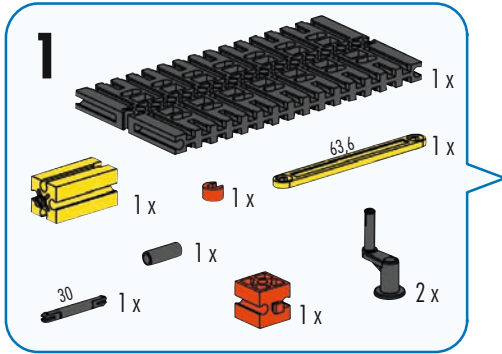

Class Set Gears

fischertechnik GmbH
Klaus-Fischer-Str. 1
72178 Waldachtal
Germany
Phone: +49 74 43/12-43 69
Fax: +49 74 43/12-45 91
info@fischertechnik.de
www.fischertechnik.de

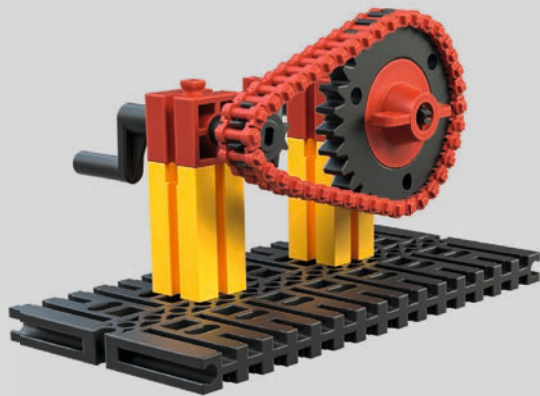

183284 - 02/21 - Co - Printed in Germany - Technische Änderungen vorbehalten - Subject to technical modifications