



ENCODER MOTOR 9V

Art. Nr. 153422

MOTOR

Voltage Suggested	9.0 DC Constant between motor terminals
Operating Temperature Range	Between 0°C to +50°C
Storage Humidity Range	Between 20% to 70%
Reduction Ratio	1:21.3
No Load Speed	200(±22) rpm
No Load Current	0.10 A max.
Stall Torque	1.3 kgcm min.
Stall Current	1.3 A max.

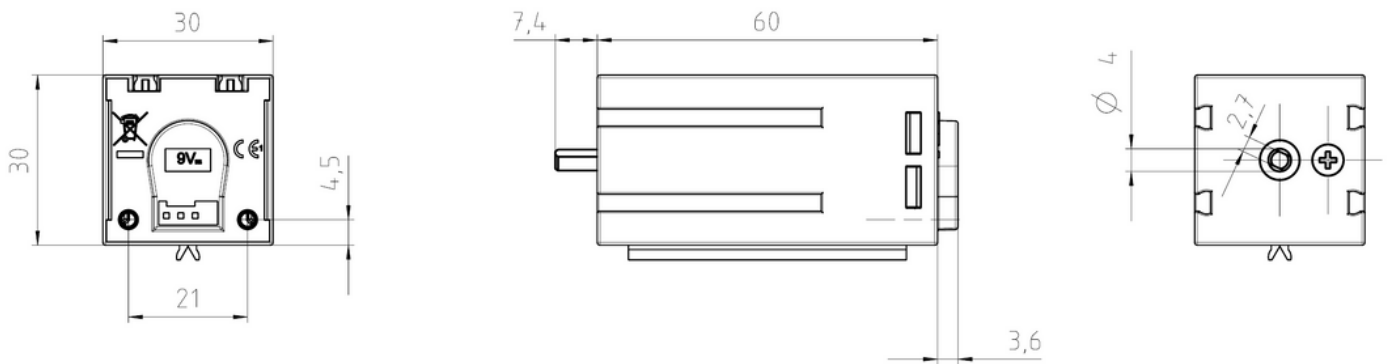

ENCODER

Signal	Push-Pull Output (0/9V), max. 10 mA
Frequency	max. 1 kHz
Connector	3-pin header
Fitting Cable	Art. Nr. 137125, Art. Nr. 168961
Supply Voltage Encoder	3.3 - 9V DC
Signal	npn open collector output, max. 2 mA

When the encoder motor is connected to a digital input of any control units (not fischertechnik controllers) a pull-up resistance of 4.7-10 kOhms is needed between the encoder signal and the encoder power supply (3.3V or 5V).

Resolution of encoder: 3 pulses (6 pulses when counting 0-1 and 1-0 edge) per round of motor. 63.9/127.8 pulses per round of the gear shaft.

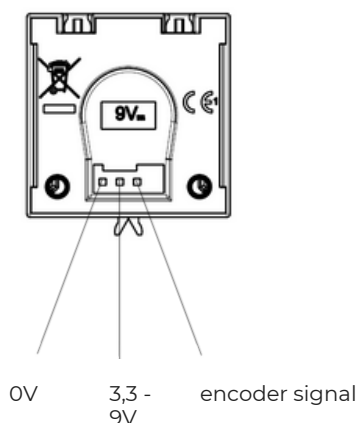

NO LOAD		AT MAX. EFFICIENCY					STALL	
SPEED (r.p.m)	CURRENT (A)	SPEED (r.p.m)	CURRENT (A)	TORQUE (g.cm)	OUT PUT (W)	EFFICIENCY (%)	CURRENT (A)	TORQUE (g.cm)
200	0.079	160	0.28	417	0.67	26.4	1	1900

REFERENCE ONLY

APPROX.: 25°C

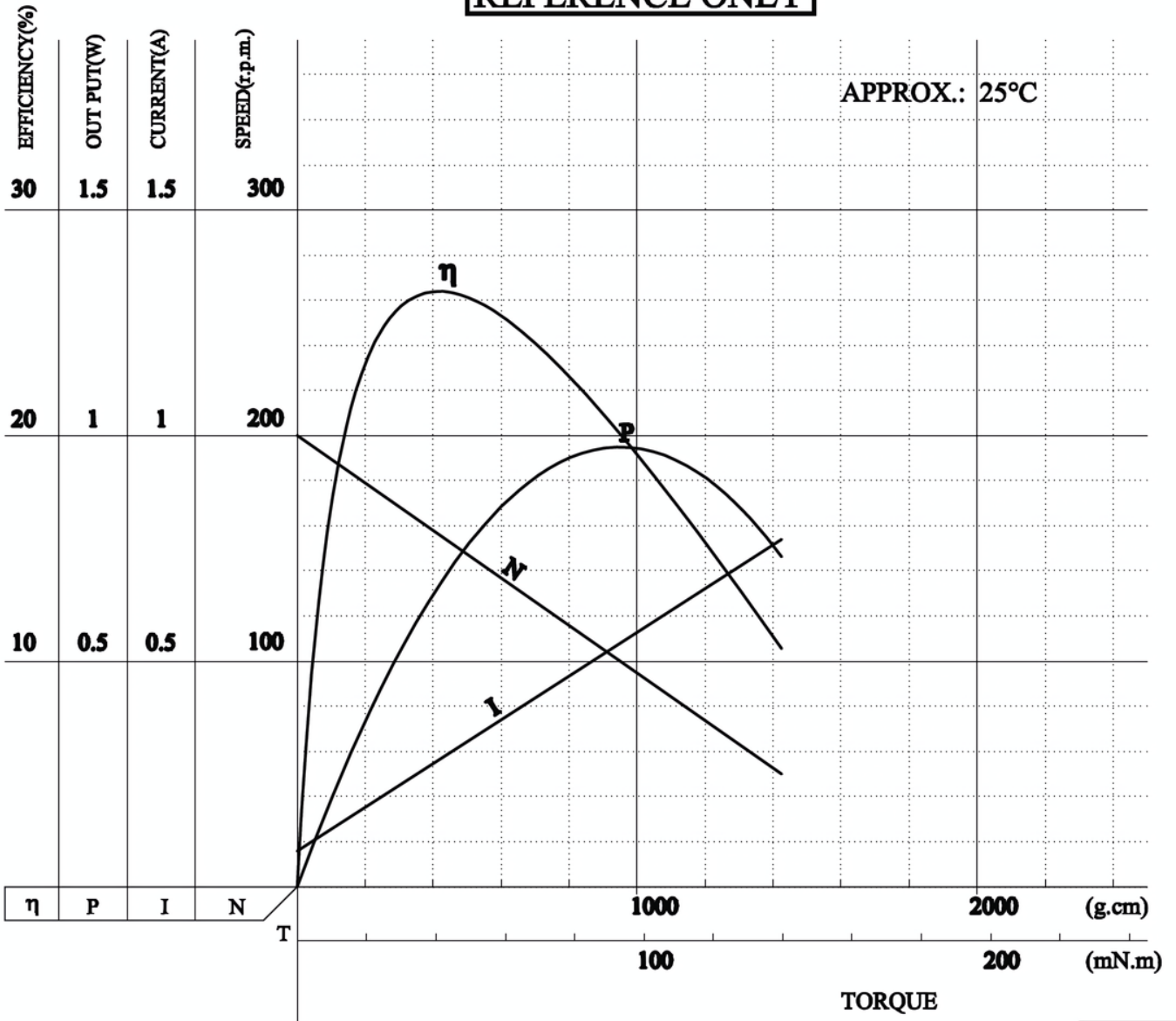



MICRO SERVO 4,8/ 6V

Art. Nr. 132292

Control System	Positive PWM control (neutral approx. 1500µs)	
Operation Voltage Range	4.8 V ~ 6.0 V	
Operation Temperature Range	-20C° ~ +60C°	
Test Voltage	At 4.8 V	At 6.0 V
Standing Torque	1.8 kgcm	2.2 kgcm
Speed	0.13 sec / 60 deg at no load	0.11 sec / 60 deg at no load
Idle Current	200 mA at stopped	220 mA at stopped
Running Current	1000 mA at no load	1200 mA at no load
Dead Band Width	8 µs	8 µs
Moving Angle	60° ± 10°	
Direction	Clock Wise / Pulse Travel 1500 to 1900 usec	
Driver Type	FET Drive	
Motor Type	Metal Gear	
Potentiometer Type	Indirect Drive	
Amplifier Type	Analog Control	
Gear Material	Metal	
Wire Length	240 mm	
Wire Gauge	26 AWG heavy duty (JR Universal)	
Plug Type	JR Plug	
Brown Wire	Negative	
Red Wire	Positive	
Orange Wire	S Single	

Servo motor in fischertechnik holder

